

SH Series

Centrifugal pumps entirely made of AISI 316 stainless steel according to EN 733 (ex DIN 24255). SH series pumps are used for water and clean liquid circulation in heating, ventilating and air conditioning systems, and for pressure boosting in industrial applications.

Available versions:

SHE Close-coupled with special motor shaft extension.

SHS With stub shaft and standard motor.

SHF With shaft extension, support, flexible coupling, base and standard motor according to EN 733 (ex DIN 24255).

Specifications

Delivery: up to 240 m³/h

Head: up to 110 m

Power supply: three-phase and single-phase 50 and 60 Hz

Power: 0.25 kW to 75 kW

Maximum operating pressure: 12 bar PN12

Temperature of pumped liquid: -10°C to +120°C

Insulation class: 155 (F)

Protection: IP55

Materials

Pump body: AISI 316 stainless steel

Impeller: AISI 316 stainless steel

Seal holder: AISI 316 stainless steel

Adapter: Aluminium or Cast iron

Mechanical seal: Ceramic/Carbon/FPM

Fill and drain plugs: AISI 316 stainless steel

Elastomers: FPM

Applications

Water distribution

Heating, ventilation

Pressure boosting

Irrigation

Industrial washing equipment

Swimming pools

Cooling and chilling

General industry

Water treatment

Heat recovery

Filtration systems

Auxiliary equipment

Available on request:

- different voltages and frequencies
- special materials for the mechanical seals and gaskets
- SFH with flexible coupling with spacer
- version with Hydrovar frequency converter



For a complete list of technical information, consult www.lowara.com

List of models, SH SERIES 50 Hz 2 poles

SIZE	kW	VERSION			
		SHEM	SHE	SHS	SHF
25-125/07	0,75	•	•	•	•
25-125/11	1,1	•	•	•	•
25-160/15	1,5	•	•	•	•
25-160/22	2,2	•	•	•	•
25-200/30	3	-	•	•	•
25-200/40	4	-	•	•	•
25-250/55	5,5	-	•	•	•
25-250/75	7,5	-	•	•	•
25-250/110	11	-	•	•	•
32-125/07	0,75	•	•	•	•
32-125/11	1,1	•	•	•	•
32-160/15	1,5	•	•	•	•
32-160/22	2,2	•	•	•	•
32-200/30	3	-	•	•	•
32-200/40	4	-	•	•	•
32-250/55	5,5	-	•	•	•
32-250/75	7,5	-	•	•	•
32-250/110	11	-	•	•	•
40-125/11	1,1	•	•	•	•
40-125/15	1,5	•	•	•	•
40-125/22	2,2	•	•	•	•
40-160/30	3	-	•	•	•
40-160/40	4	-	•	•	•
40-200/55	5,5	-	•	•	•
40-200/75	7,5	-	•	•	•
40-250/92	9,2	-	•	-	-
40-250/110A	11	-	-	•	•
40-250/110	11	-	•	•	•
40-250/150	15	-	•	•	•
50-125/22	2,2	•	•	•	•
50-125/30	3	-	•	•	•
50-125/40	4	-	•	•	•
50-160/55	5,5	-	•	•	•
50-160/75	7,5	-	•	•	•
50-200/92	9,2	-	•	-	-
50-200/110A	11	-	-	•	•
50-200/110	11	-	•	•	•
50-250/150	15	-	•	•	•
50-250/185	18,5	-	•	•	•
50-250/220	22	-	•	•	•
65-160/40	4	-	•	•	•
65-160/55	5,5	-	•	•	•
65-160/75	7,5	-	•	•	•
65-160/92	9,2	-	•	-	-
65-160/110A	11	-	-	•	•
65-160/110	11	-	•	•	•
65-200/150	15	-	•	•	•
65-200/185	18,5	-	•	•	•
65-200/220	22	-	•	•	•
65-250/300	30	-	-	•	•
65-250/370	37	-	-	•	•
80-160/110	11	-	•	•	•
80-160/150	15	-	•	•	•
80-160/185	18,5	-	•	•	•
80-200/220	22	-	•	•	•
80-200/300	30	-	-	•	•
80-200/370	37	-	-	•	•
80-250/450	45	-	-	-	•
80-250/550	55	-	-	-	•
80-250/750	75	-	-	-	•

• = Available

sh_she-shs-shf_2p50_b_tem

4 poles

SIZE	kW	VERSION		
		SHE4	SHS4	SHF4
25-125/02A	0,25	•	-	•
25-125/02	0,25	•	-	•
25-160/02	0,25	•	-	•
25-160/03	0,37	•	-	•
25-200/03	0,37	•	-	•
25-200/05	0,55	•	-	•
25-250/07	0,75	•	•	•
25-250/11	1,1	•	•	•
25-250/15	1,5	•	•	•
32-125/02A	0,25	•	-	•
32-125/02	0,25	•	-	•
32-160/02	0,25	•	-	•
32-160/03	0,37	•	-	•
32-200/03	0,37	•	-	•
32-200/05	0,55	•	-	•
32-250/07	0,75	•	•	•
32-250/11	1,1	•	•	•
32-250/15	1,5	•	•	•
40-125/02A	0,25	•	-	•
40-125/02	0,25	•	-	•
40-125/03	0,37	•	-	•
40-160/03	0,37	•	-	•
40-160/05	0,5	•	-	•
40-200/07	0,75	•	•	•
40-200/11	1,1	•	•	•
40-250/11	1,1	•	•	•
40-250/15	1,5	•	•	•
40-250/22	2,2	•	•	•
50-125/03A	0,37	•	-	•
50-125/03	0,37	•	-	•
50-125/05	0,5	•	-	•
50-160/07	0,75	•	•	•
50-160/11	1,1	•	•	•
50-200/11	1,1	•	•	•
50-200/15	1,5	•	•	•
50-250/22A	2,2	•	•	•
50-250/22	2,2	•	•	•
50-250/30	3	•	•	•
65-160/05	0,5	•	•	•
65-160/07	0,75	•	•	•
65-160/11A	1,1	•	•	•
65-160/11	1,1	•	•	•
65-160/15	1,5	•	•	•
65-200/15	1,5	•	•	•
65-200/22	2,2	•	•	•
65-200/30	3	•	•	•
65-250/40	4	•	•	•
65-250/55	5,5	•	•	•
80-160/15	1,5	•	•	•
80-160/22A	2,2	•	•	•
80-160/22	2,2	•	•	•
80-200/30	3	•	•	•
80-200/40	4	•	•	•
80-250/55	5,5	•	•	•
80-250/75	7,5	•	•	•
80-250/110	11	•	•	•

• = Available

sh_she4-shs4-shf4_4p50-en_c_tem

SH SERIES

Hydraulic performance table at 50 Hz, 2 poles

PUMP TYPE	RATED POWER		Q = DELIVERY																			
	kW	HP	l/min 0	150	200	250	300	400	450	600	700	800	900	1000	1200	1500	1800	2000	2500	3150	3700	
			m ³ /h 0	9	12	15	18	24	27	36	42	48	54	60	72	90	108	120	150	189	222	
H = TOTAL HEAD METRES COLUMN OF WATER																						
25-125/07 *	0,75	1	17,3	14,2	12,5	10,5	8,4															
25-125/11 *	1,1	1,5	22,3	18,9	17	14,7	12,3															
25-160/15 *	1,5	2	27,7	24,8	22,9	20,5	17,9	11,9														
25-160/22 *	2,2	3	34,6	31,5	29,4	27	24,2	17,7														
25-200/30	3	4	44,9	39,2	36,7	33,8	30,4	22,4														
25-200/40	4	5,5	54,5	49,4	46,8	43,8	40,3	31,9	27													
25-250/55	5,5	7,5	61,4	55,8	53,2	50,3	47	39,2														
25-250/75	7,5	10	75,9	69,3	66,5	63,2	59,6	51,1														
25-250/110	11	15	87,5	81,5	78,7	75,4	71,8	63,3	58,4													
32-125/07 *	0,75	1	16,6	14,4	13	11,3	9,5															
32-125/11 *	1,1	1,5	21,6	19,4	17,8	16,2	14,2	9,8														
32-160/15 *	1,5	2	27,6	24,6	22,7	20,6	18,1	12,7														
32-160/22 *	2,2	3	35	32,5	31	29	26,6	21	18													
32-200/30	3	4	43,7	38,5	36	33	30	22,3														
32-200/40	4	5,5	53,5	49	46,8	44	41	33,8	28,8													
32-250/55	5,5	7,5	61,7	56,7	54,2	51,2	47,9	40														
32-250/75	7,5	10	74,1	68,9	66,2	63	60	52,2														
32-250/110	11	15	86,2	80,1	77,5	74,3	71	63,3	58,7													
40-125/11 *	1,1	1,5	14,4				12,5	10,9	10	7												
40-125/15 *	1,5	2	17,5				16	14,4	13,4	10,2	8											
40-125/22 *	2,2	3	25,3				22,2	20,4	19,5	15,9	13,2											
40-160/30	3	4	32,2				29,5	26,9	25,4	20,8	17											
40-160/40	4	5,5	38				35,5	33,2	31,7	26,7	22,8	18,5										
40-200/55	5,5	7,5	49,1				46,4	43,8	42	36,2	31	25										
40-200/75	7,5	10	58,2				55,1	52,3	50,8	45	40	34,5										
40-250/ **	**	**	64,9				62	59,5	58	51,5	44,6											
40-250/110	11	15	74,7				71,4	69	67,8	61,5	55,2											
40-250/150	15	20	87,7				84,2	81,5	80	74,3	69,2	62,5										
50-125/22 *	2,2	3	17,2						14,6	13,4	12,2	11	9,5	6,5								
50-125/30	3	4	21,7						18,8	17,5	16,3	14,8	13,4	10,5								
50-125/40	4	5,5	25,7						23,3	22,2	20,8	19,3	18	15								
50-160/55	5,5	7,5	34,1						30,6	29,2	27,6	28	26,6	19,8								
50-160/75	7,5	10	40,8						37,5	36,2	34,8	25,8	24	27	18,6							
50-200/ **	**	**	53						47,5	45,3	42,8	40	36,8	29,8								
50-200/110	11	15	60,1						55	52,8	50,3	47,5	44,3	37,5								
50-250/150	15	20	70,2						66,6	65	63,3	61	58,3	51								
50-250/185	19	25	80						75	73,2	71,4	69	66,3	59,5								
50-250/220	22	30	88,9						84,6	82,8	80,7	78,5	75,8	69,5								
65-160/40	4	5,5	19,6								16,8	16	15,2	13,5	10,8	7,6						
65-160/55	5,5	7,5	24,2								21,4	20,7	19,8	18	15,2	11,8						
65-160/75	7,5	10	28,2								26	25,3	24,7	23	20	16,8	14,5					
65-160/ **	**	**	38,2								35,4	34,3	33	30	25,5	20						
65-160/110	11	15	43,2								40,8	39,8	38,5	35,5	30,6	25,4	21,4					
65-200/150	15	20	53									48,8	47,5	44,3	38,5	32						
65-200/185	19	25	60,2									56,5	55,3	52	47	40	35,4					
65-200/220	22	30	68									64,4	63,3	60	55	49	44,5					
65-250/300	30	40	84,3										81,7	79,5	75	69	64					
65-250/370	37	50	98											95,3	93	88	82,5	78				
80-160/110	11	15	33,6											31,9	30	27,5	25,5	20,5	12,5			
80-160/150	15	20	40,3											38,8	37	34,5	33	27,5	20			
80-160/185	19	25	47,2											45,7	44	41,5	40	35	27,5	19,5		
80-200/220	22	30	53												49,8	47,5	46	41	33,5			
80-200/300	30	40	63,6												61,2	59	57	52	44	36,5		
80-200/370	37	50	71,4												69,5	67,5	66	61	53,5	46		
80-250/450***	45	60	83,5												80,5	78	76	70	61			
80-250/550***	55	75	95,7												93,6	91	89	83,5	75	64,6		
80-250/750***	75	100	112												110	108	106	101	92	82		

* A single-phase version (SHEM) is also available

** /92 = 9.2kW - 12.5HP SHE ** /110 = 11kW - 15HP SHS

*** Only the SHF version is available

Performances according to ISO standards 9906 - Annex A.

she-shs-shf-2p50-en_d_th

SH SERIES

Hydraulic performance table at 50 Hz, 4 poles

PUMP TYPE	RATED POWER		Q = DELIVERY																							
	kW	HP	l/min	75	100	125	150	200	250	300	350	400	450	500	600	750	1000	1200	1800	2000	2200					
			m ³ /h	4,5	6	7,5	9	12	15	18	21	24	27	30	36	45	60	72	108	120	132					
H = TOTAL HEAD METRES COLUMN OF WATER																										
25-125/02A *	0,25	0,33	4,4	3,8	3,4	2,9	2,4																			
25-125/02 *	0,25	0,33	5,6	4,8	4,3	3,8	3,2																			
25-160/02 *	0,25	0,33	6,9	6,1	5,6	5,1	4,4	2,9																		
25-160/03 *	0,37	0,5	8,6	7,8	7,2	6,6	5,9	4,3																		
25-200/03 *	0,37	0,5	11	9,4	8,7	8	7,1	5,1																		
25-200/05 *	0,55	0,75	13,4	12	11,3	10,5	9,6	7,5																		
25-250/07	0,75	1	14,9	13,3	12,6	11,9	11	9	6,7																	
25-250/11	1,1	1,5	18,8	17,1	16,3	15,5	14,6	12,4	9,9																	
25-250/15	1,5	2	21,5	19,9	19,1	18,3	17,3	15,1	12,6																	
32-125/02A *	0,25	0,33	4,4	3,9	3,6	3,1	2,7	1,6																		
32-125/02 *	0,25	0,33	5,5	5	4,7	4,3	3,8	2,7																		
32-160/02 *	0,25	0,33	6,9	5,9	5,4	4,9	4,4	2,9																		
32-160/03 *	0,37	0,5	8,6	7,8	7,4	6,9	6,4	5,2	3,6																	
32-200/03 *	0,37	0,5	10,8	9,4	8,7	7,9	7	5,1																		
32-200/05 *	0,55	0,75	13,2	12	11,3	10,6	9,8	7,8	5,4																	
32-250/07	0,75	1	14,5	13	12,3	11,6	10,8	8,9	6,5																	
32-250/11	1,1	1,5	18,4	16,8	16,1	15,3	14,4	12,5	10,1																	
32-250/15	1,5	2	21,3	19,7	19	18,2	17,5	15,2	12,8																	
40-125/02A *	0,25	0,33	3,5				3	2,7	2,3	1,8	1,3															
40-125/02 *	0,25	0,33	5,4				4,8	4,4	3,9	3,3	2,7	2														
40-125/03 *	0,37	0,5	6,3				5,7	5,2	4,7	4	3,3	2,7														
40-160/03 *	0,37	0,5	8				7,2	6,6	5,9	5,2	4	3,1														
40-160/05 *	0,55	0,75	9,2				8,5	7,9	7,2	6,4	5,4	4,4														
40-200/07	0,75	1	11,9				11,2	10,5	9,7	8,6	7,3	5,8														
40-200/11	1,1	1,5	14,2				13,3	12,7	11,8	10,8	9,5	8														
40-250/11	1,1	1,5	15,7				15	14	13	11,9	10,3															
40-250/15	1,5	2	18,1				17	16,3	15,6	14,5	13	11,4														
40-250/22	2,2	3	21,5				20,3	19,7	18,8	17,7	16,3	14,8														
50-125/03A *	0,37	0,5	4,4							3,8	3,6	3,3	3	2,7	1,9											
50-125/03 *	0,37	0,5	5,4							4,6	4,3	4	3,7	3,3	2,6											
50-125/05 *	0,55	0,75	6,4							5,6	5,3	5	4,7	4,3	3,6	2,3										
50-160/07	0,75	1	8,2							7,3	7	6,7	6,3	5,8	5											
50-160/11	1,1	1,5	9,9							8,8	8,5	8,2	7,8	7,5	6,5	4,8										
50-200/11	1,1	1,5	12,8							11,2	10,7	10	9,3	8,6	6,8											
50-200/15	1,5	2	14,7							13	12,4	11,8	11,2	10,3	8,7	5,5										
50-250/22A	2,2	3	17,5							16	15,5	15	14,3	13,8	12											
50-250/22	2,2	3	19,4							17,8	17,3	16,8	16,2	15,4	13,8											
50-250/30	3	4	21,9							20,5	20,2	19,6	19	18,4	16,7	13,5										
65-160/05	0,55	0,75	5,4									4,2	3,9	3,7	3,2	2,5										
65-160/07	0,75	1	6,4									5,3	5,1	4,8	4,4	3,6										
65-160/11A	1,1	1,5	7,6									7	6,3	6,1	5,7	4,9	3,4									
65-160/11	1,1	1,5	9,4									8,5	8,2	8	7	5,9	3,4									
65-160/15	1,5	2	10,6									9,7	9,5	9,2	8,5	7,3	4,9									
65-200/15	1,5	2	11,9										10,6	10,2	9,3	7,9	5,1									
65-200/22	2,2	3	14,4										13,2	12,8	12	10,6	7,8									
65-200/30	3	4	17,5										16,6	16,3	15,6	14,2	11,7	9,3								
65-250/40	4	5,5	20,7											19,5	18,8	17,7	15	12								
65-250/55	5,5	7,5	24												23,2	22,7	21,4	19	16,4							
80-160/15	1,5	2	8,3												7,6	7	6	5,2								
80-160/22A	2,2	3	9,6													9	8,5	7,5	6,5	3,2						
80-160/22	2,2	3	11													10,4	9,8	9	8	4,5						
80-200/30	3	4	12,9														12	10,8	9,8	6,1	4,6					
80-200/40	4	5,5	16,1															15,4	14,3	11,3	9,7	8,4	7			
80-250/55	5,5	7,5	20,3																19,5	18,4	17,3	12,3	10,1			
80-250/75	7,5	1	23,1																	22,2	21,3	20,3	16,1	14,2	12,2	
80-250/110	11	15	26,7																		26,1	25,2	24,2	20,2	18,6	16,8

* SHS4 version is not available.

she4-shs4-shf4-4p50-en_f_th

Performances according to ISO standards 9906 - Annex A.

SH SERIES

Operating characteristics at 50 Hz, 2 poles

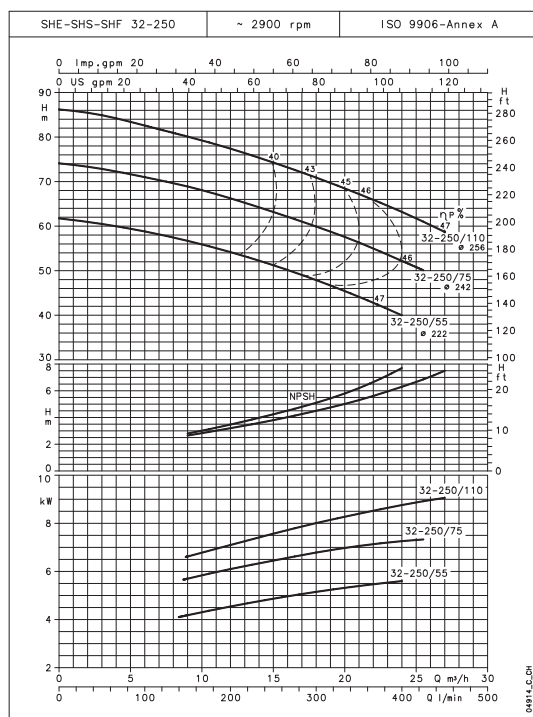
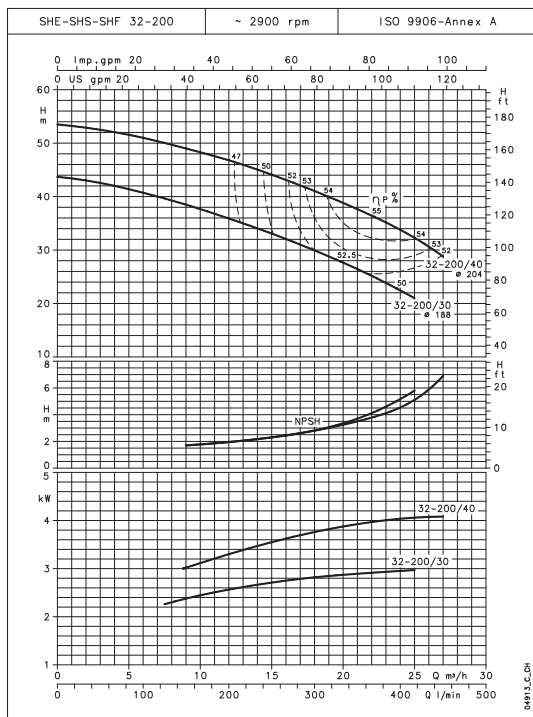
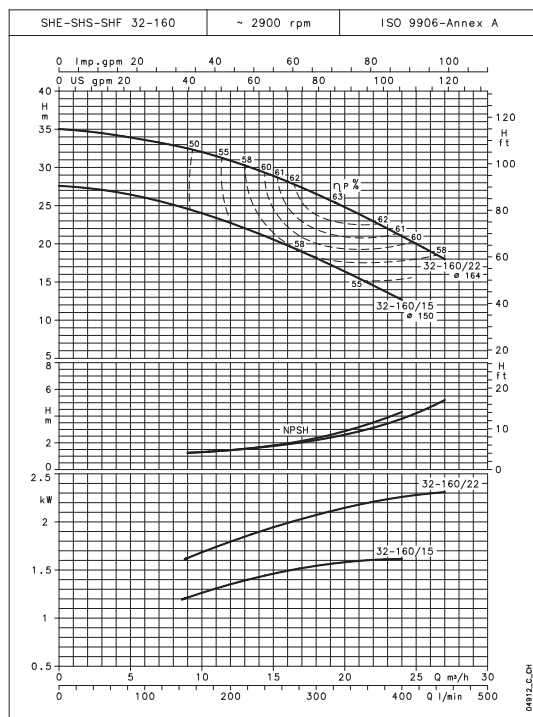
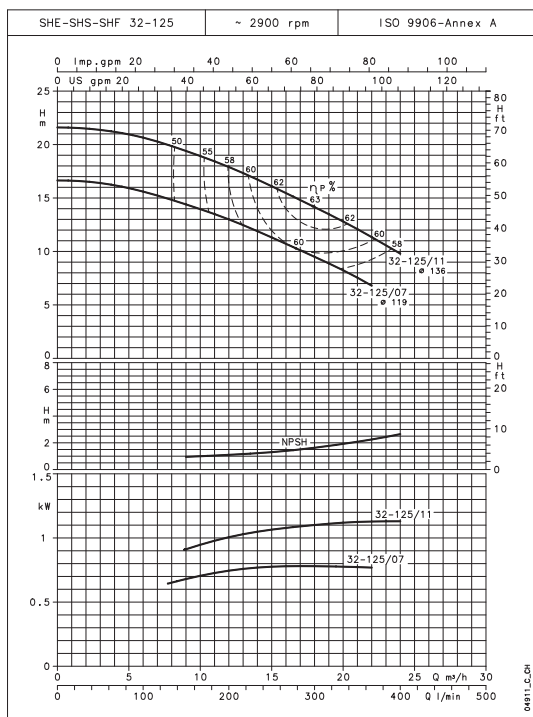

These NPSH values are valid in laboratory conditions; for practical purposes, values should be increased by a 0.5 m safety margin.

These performances are valid for liquids with density $\rho = 1.0 \text{ kg/dm}^3$ and kinematic viscosity $\nu = 1 \text{ mm}^2/\text{s}$.

SH SERIES

Operating characteristics at 50 Hz, 2 poles

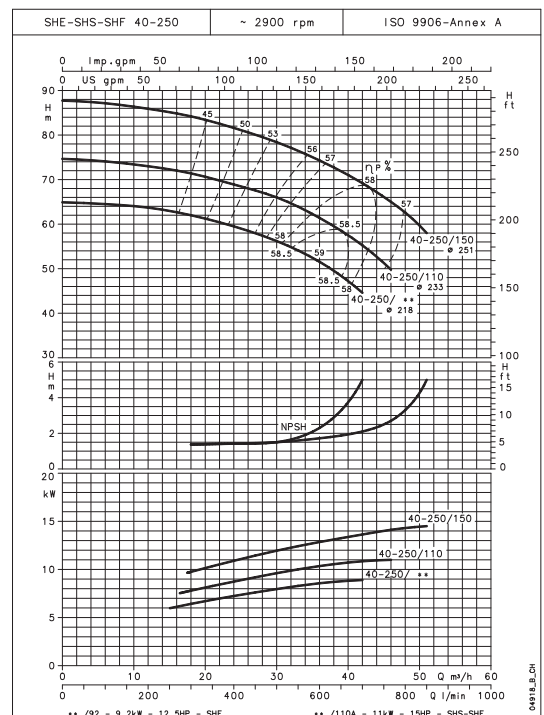
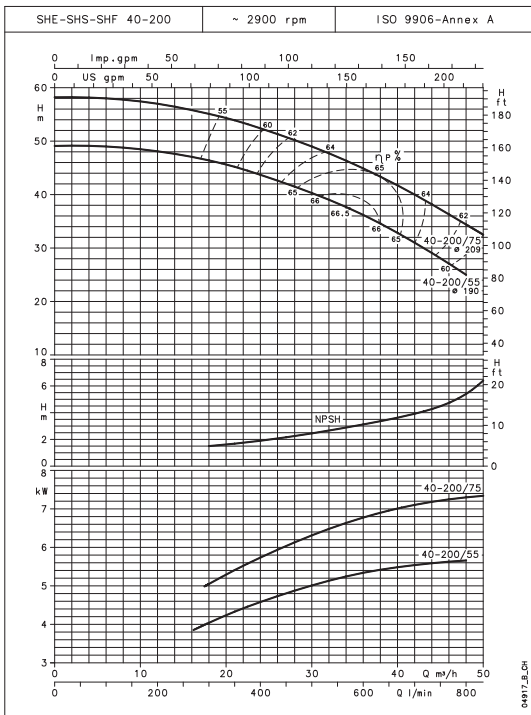
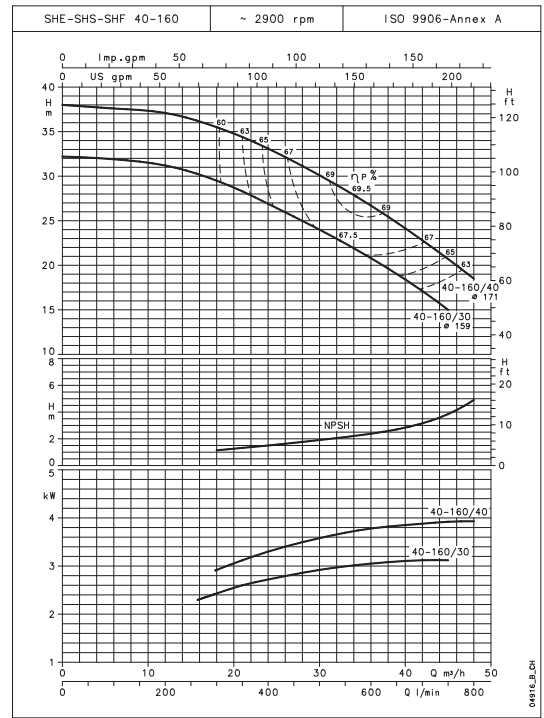
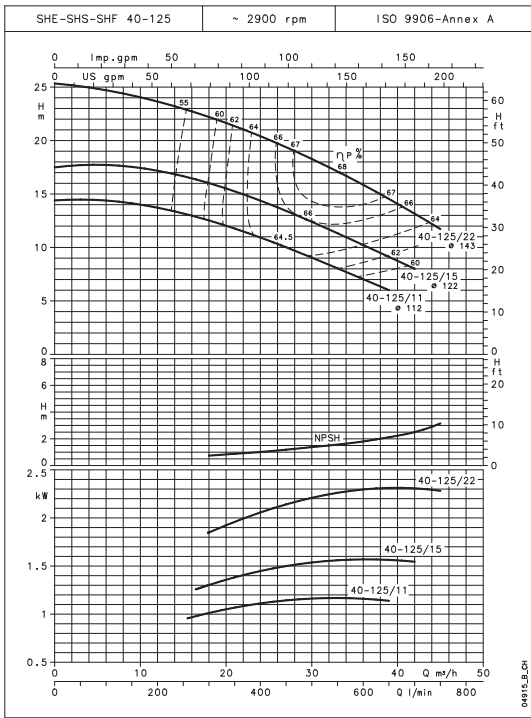

These NPSH values are valid in laboratory conditions; for practical purposes, values should be increased by a 0.5 m safety margin.

These performances are valid for liquids with density $\rho = 1.0 \text{ kg/dm}^3$ and kinematic viscosity $\nu = 1 \text{ mm}^2/\text{s}$.

SH SERIES

Operating characteristics at 50 Hz, 2 poles

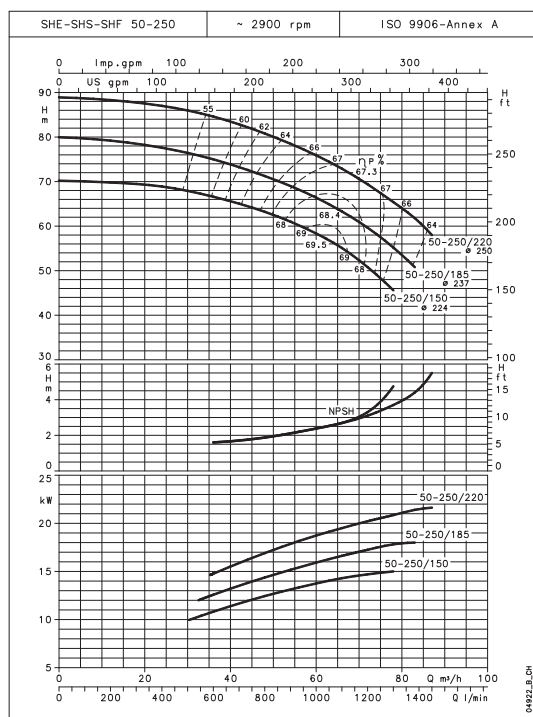
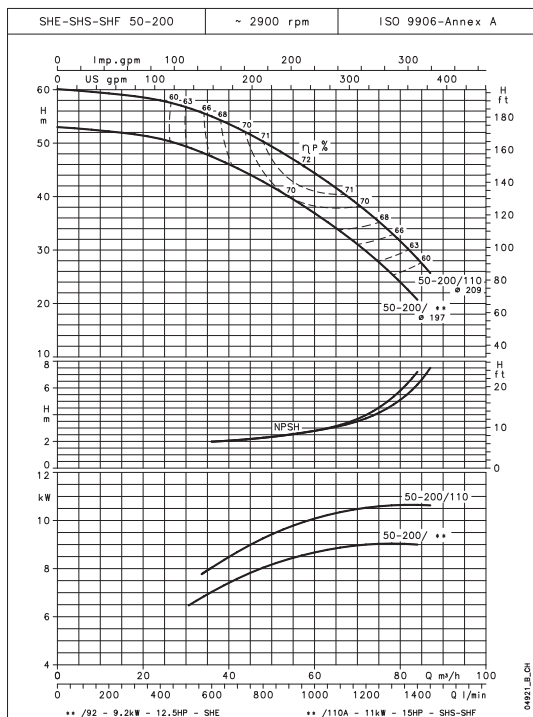
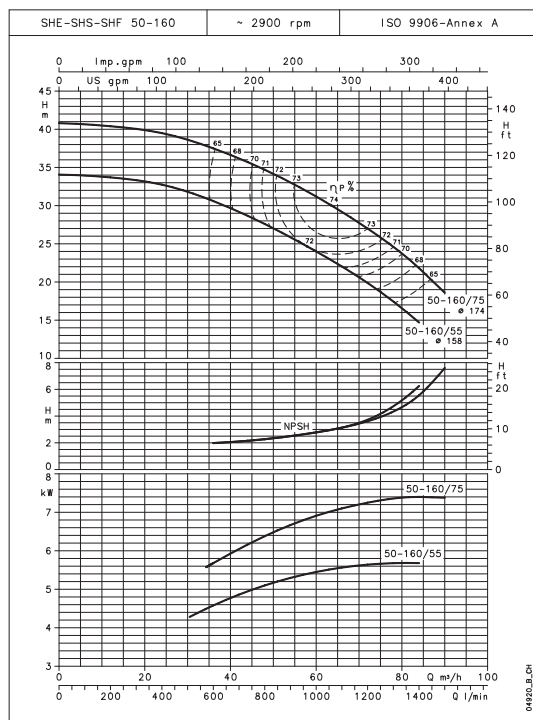
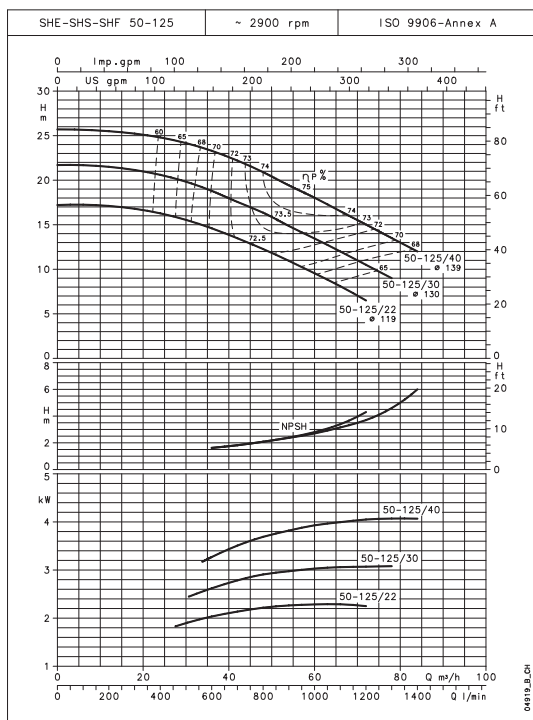

These NPSH values are valid in laboratory conditions; for practical purposes, values should be increased by a 0.5 m safety margin.

These performances are valid for liquids with density $\rho = 1.0 \text{ kg/dm}^3$ and kinematic viscosity $\nu = 1 \text{ mm}^2/\text{s}$.

SH SERIES

Operating characteristics at 50 Hz, 2 poles

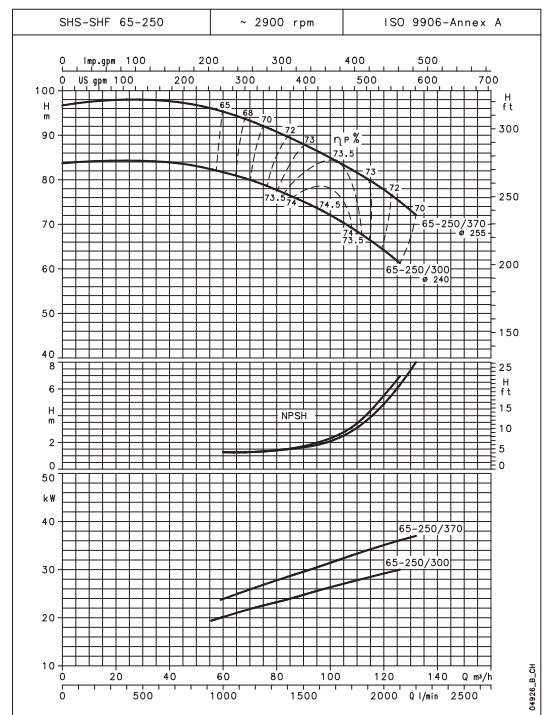
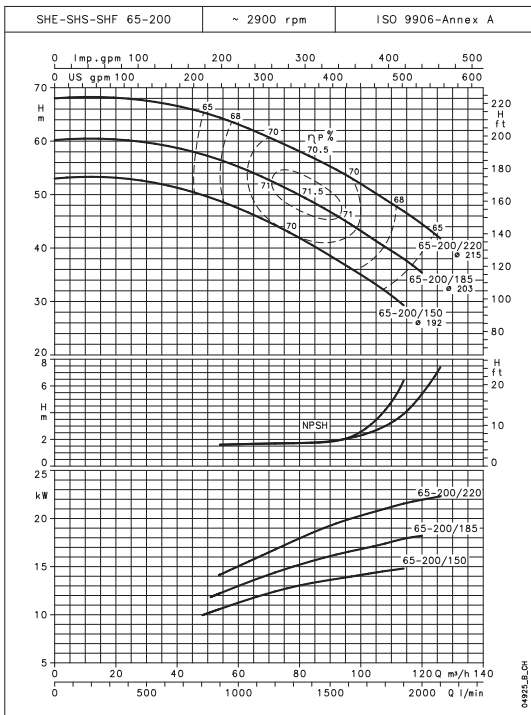
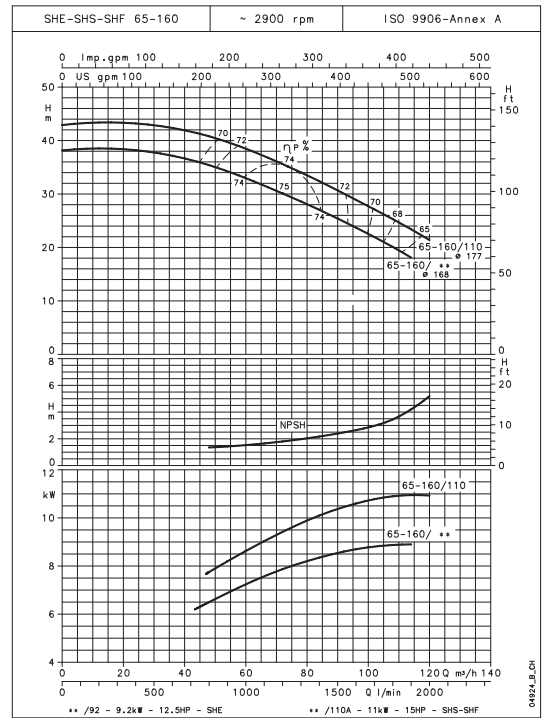
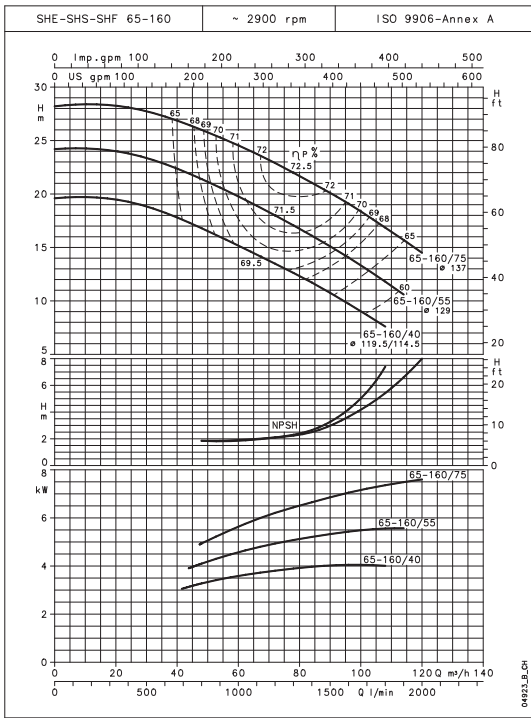

These NPSH values are valid in laboratory conditions; for practical purposes, values should be increased by a 0.5 m safety margin.

These performances are valid for liquids with density $\rho = 1.0 \text{ kg/dm}^3$ and kinematic viscosity $\nu = 1 \text{ mm}^2/\text{s}$.

SH SERIES

Operating characteristics at 50 Hz, 2 poles

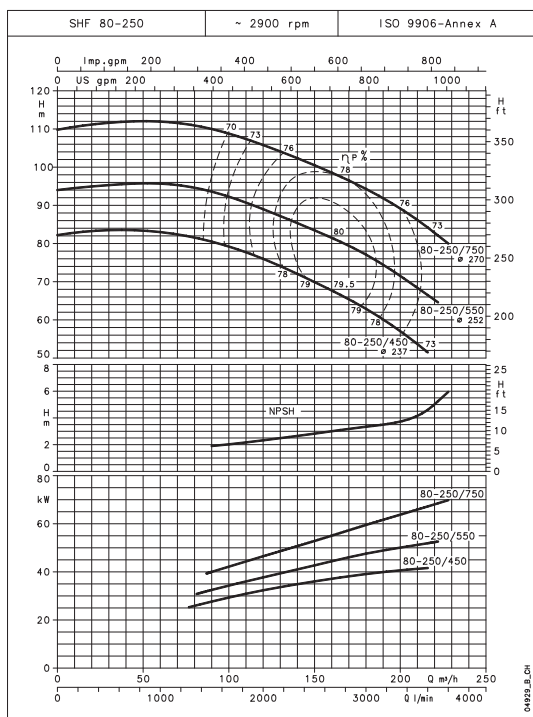
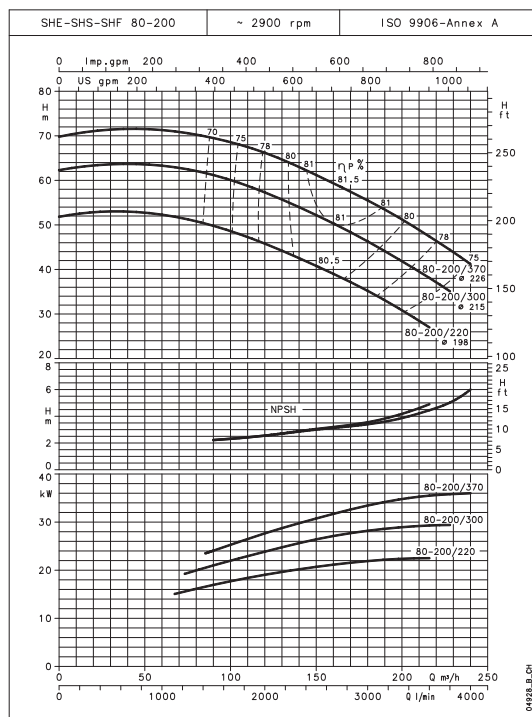
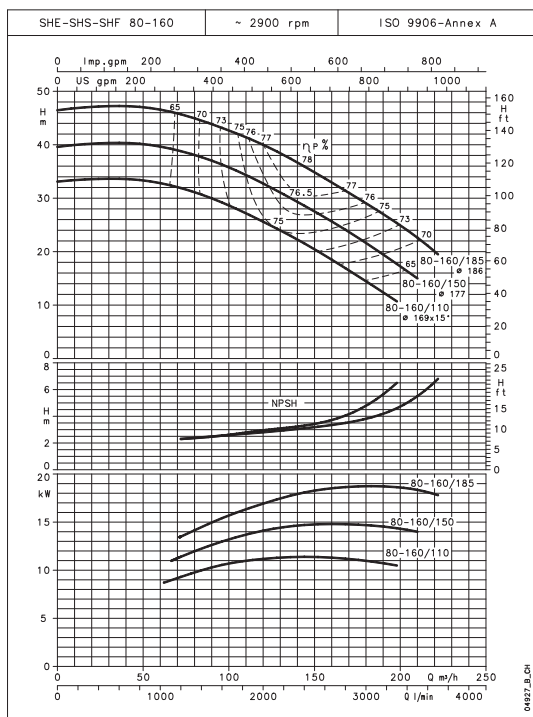

These NPSH values are valid in laboratory conditions; for practical purposes, values should be increased by a 0.5 m safety margin.

These performances are valid for liquids with density $\rho = 1.0 \text{ kg/dm}^3$ and kinematic viscosity $\nu = 1 \text{ mm}^2/\text{s}$.

SH SERIES

Operating characteristics at 50 Hz, 4 poles

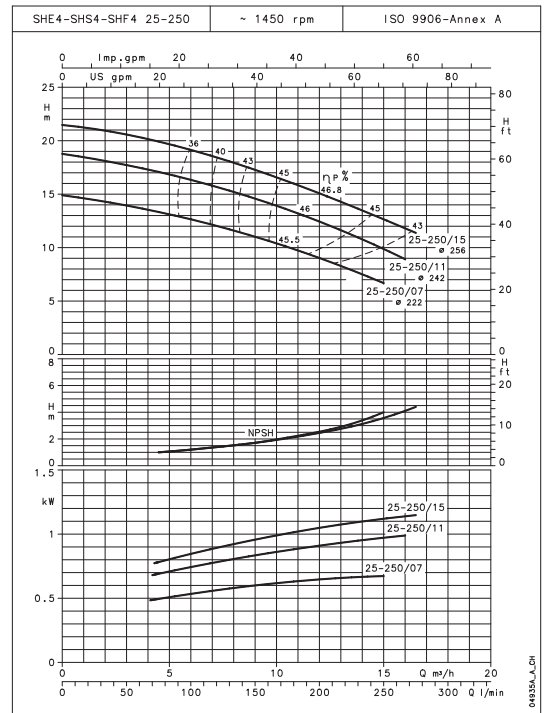
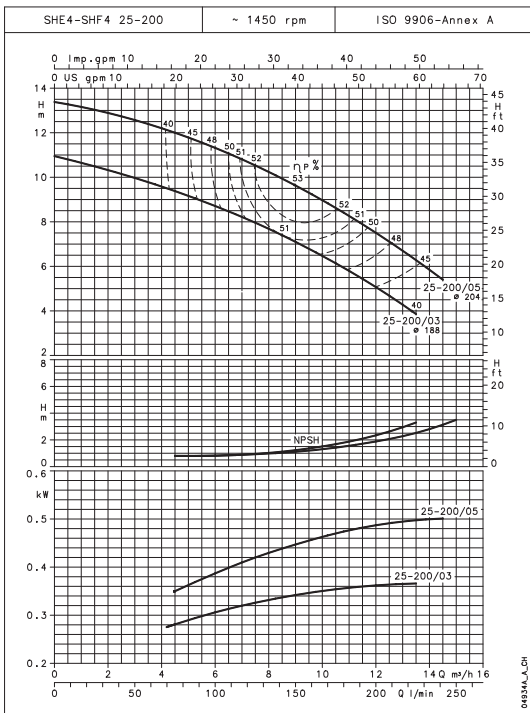
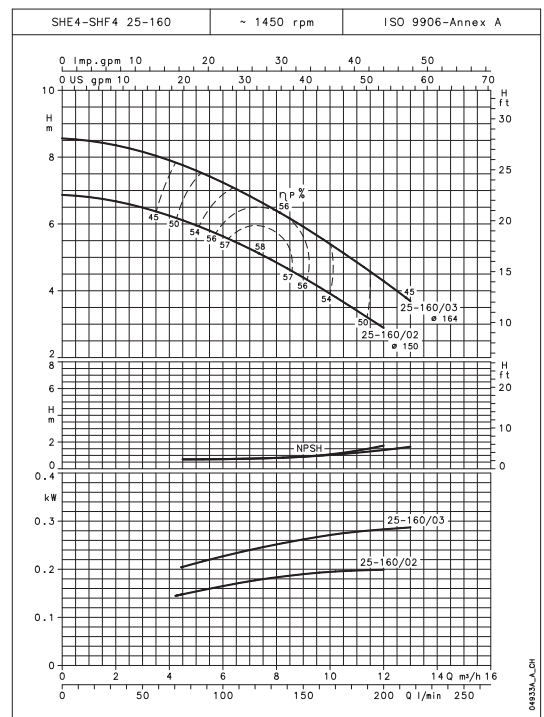
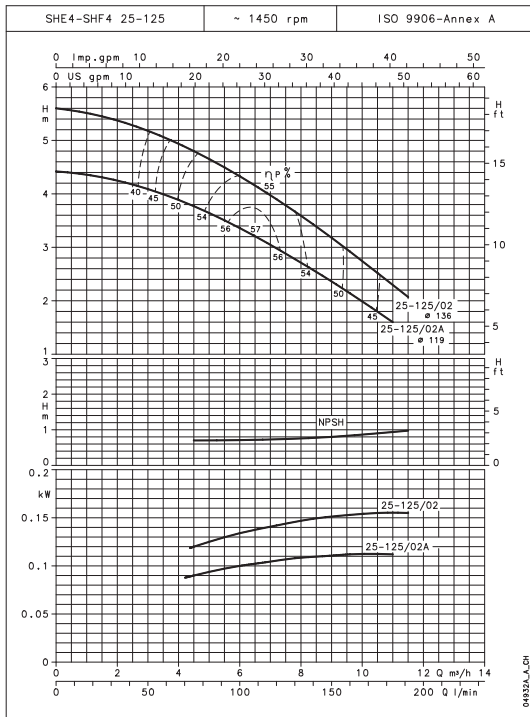

These NPSH values are valid in laboratory conditions; for practical purposes, values should be increased by a 0.5 m safety margin.

These performances are valid for liquids with density $\rho = 1.0 \text{ kg/dm}^3$ and kinematic viscosity $\nu = 1 \text{ mm}^2/\text{s}$.

SH SERIES

Operating characteristics at 50 Hz, 4 poles

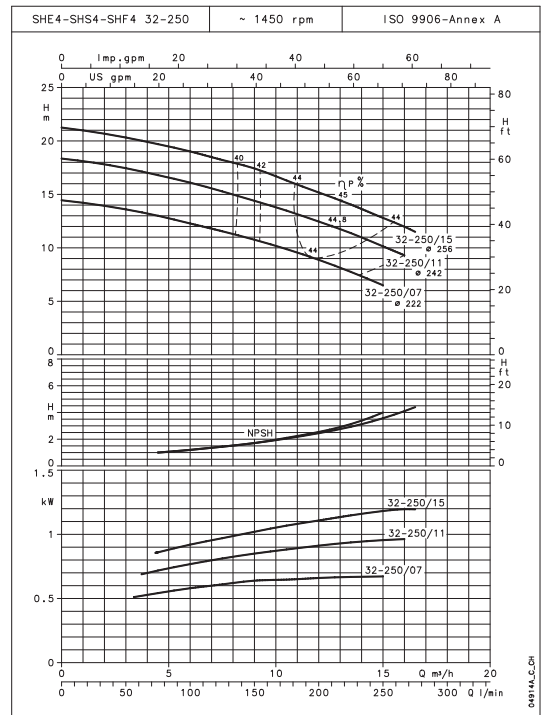
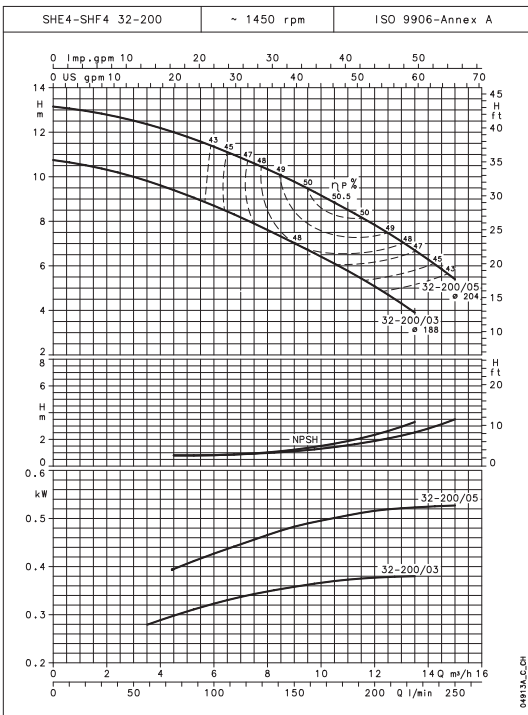
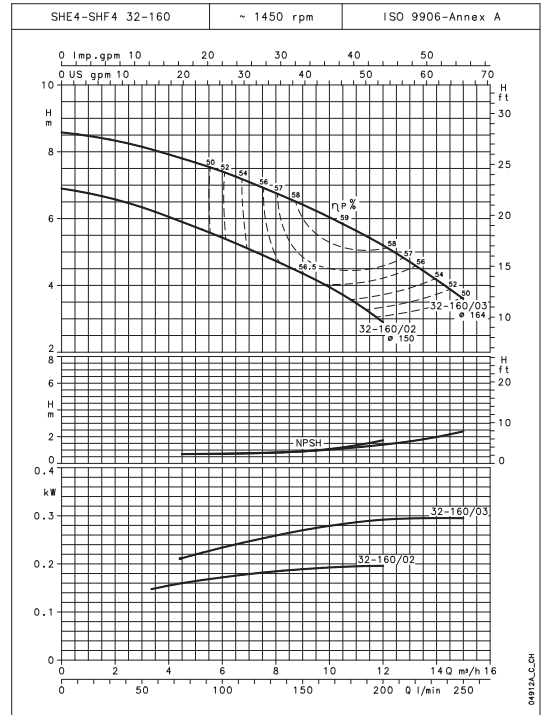
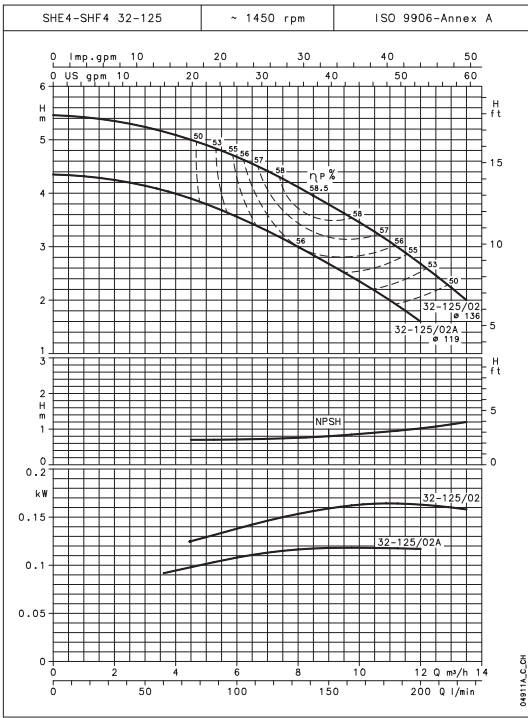

These NPSH values are valid in laboratory conditions; for practical purposes, values should be increased by a 0.5 m safety margin.

These performances are valid for liquids with density $\rho = 1.0 \text{ kg/dm}^3$ and kinematic viscosity $\nu = 1 \text{ mm}^2/\text{s}$.

SH SERIES

Operating characteristics at 50 Hz, 4 poles

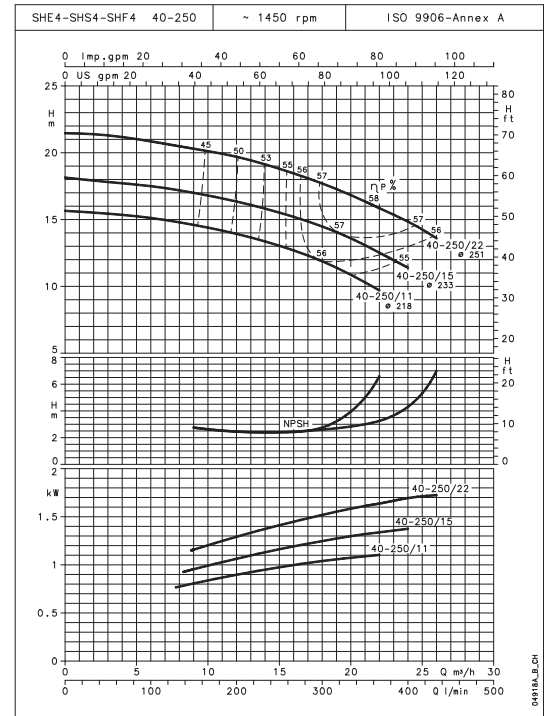
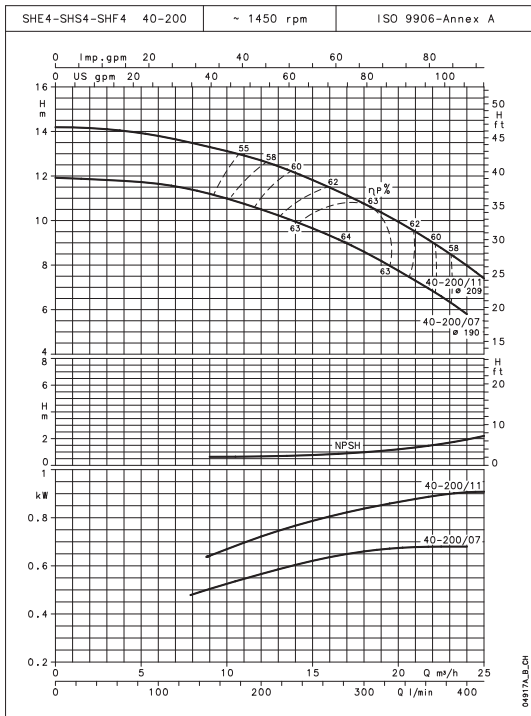
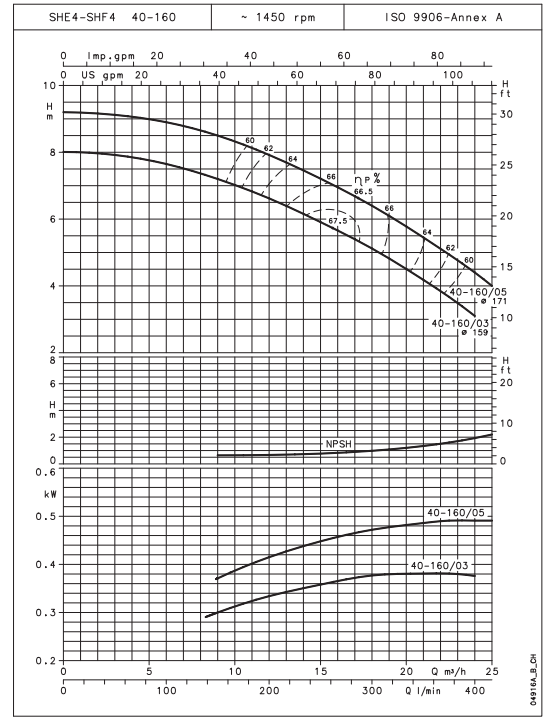
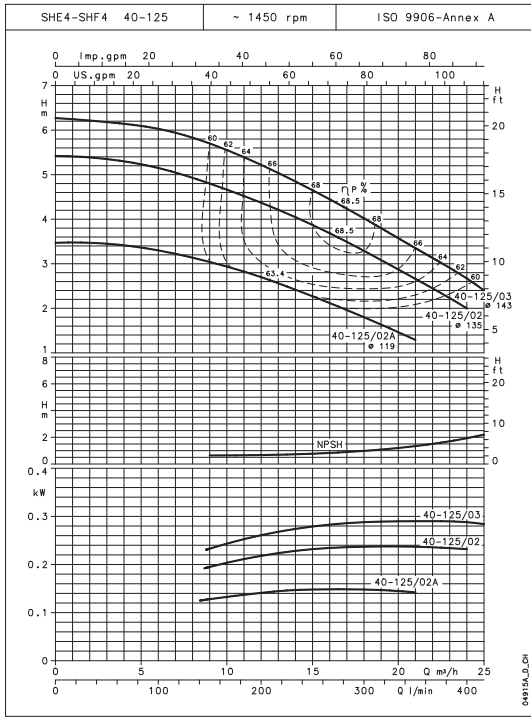

These NPSH values are valid in laboratory conditions; for practical purposes, values should be increased by a 0.5 m safety margin.

These performances are valid for liquids with density $\rho = 1.0 \text{ kg/dm}^3$ and kinematic viscosity $\nu = 1 \text{ mm}^2/\text{s}$.

SH SERIES

Operating characteristics at 50 Hz, 4 poles

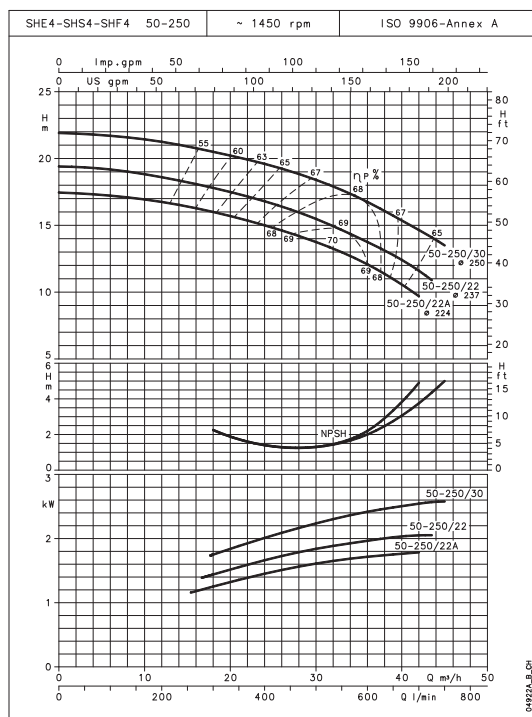
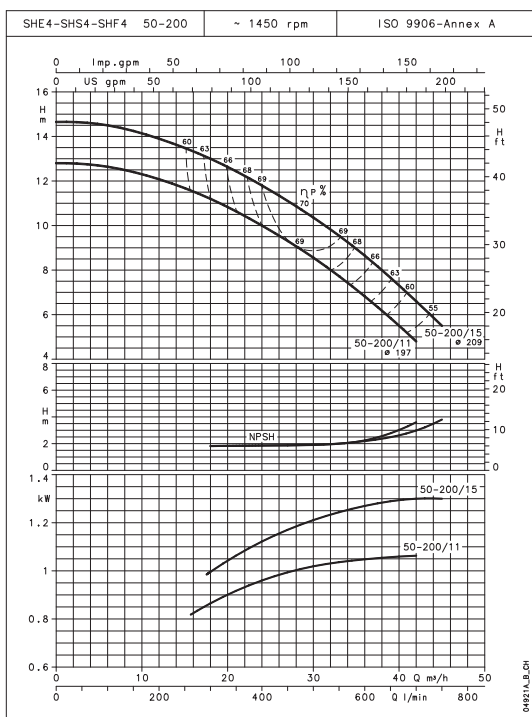
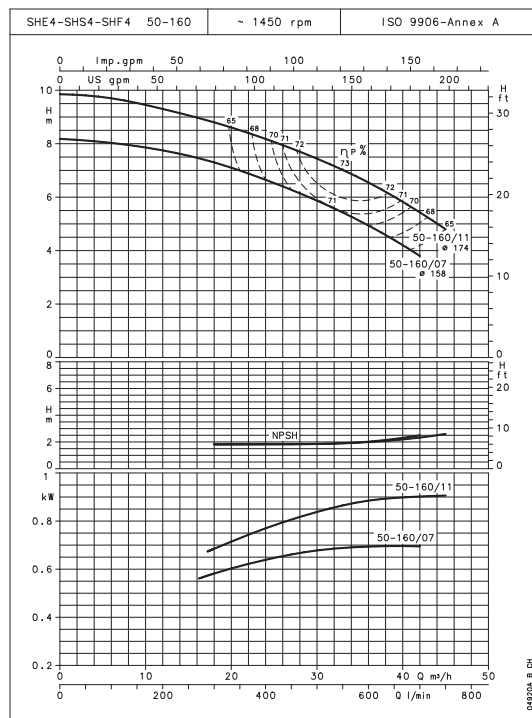
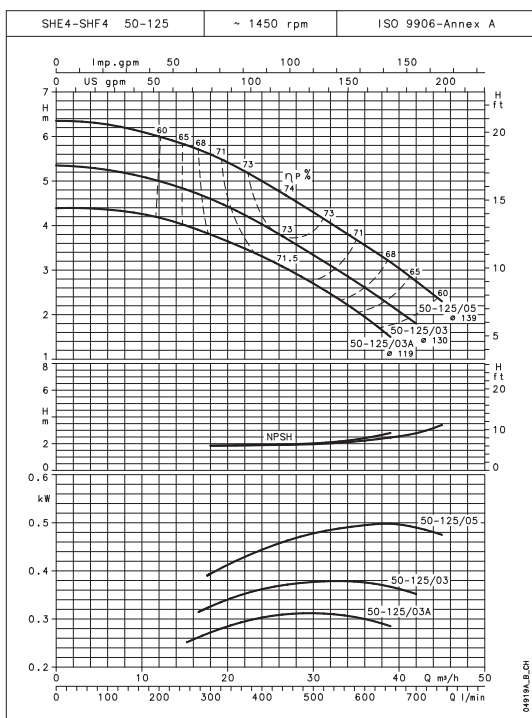

These NPSH values are valid in laboratory conditions; for practical purposes, values should be increased by a 0.5 m safety margin.

These performances are valid for liquids with density $\rho = 1.0 \text{ kg/dm}^3$ and kinematic viscosity $\nu = 1 \text{ mm}^2/\text{s}$.

SH SERIES

Operating characteristics at 50 Hz, 4 poles

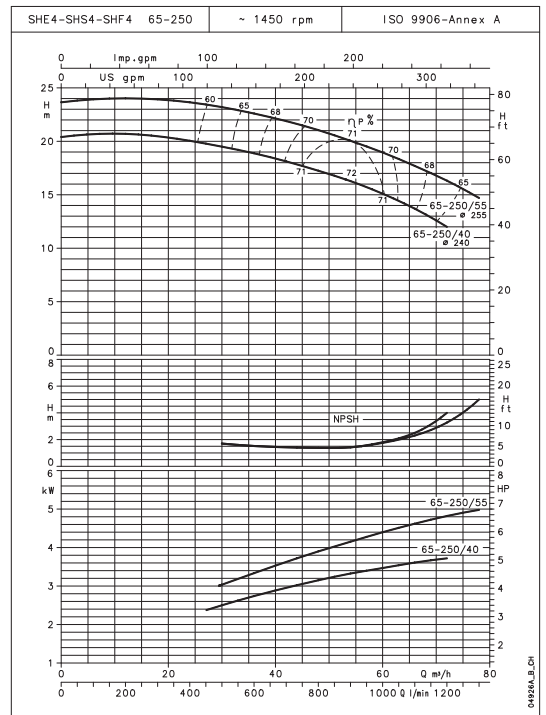
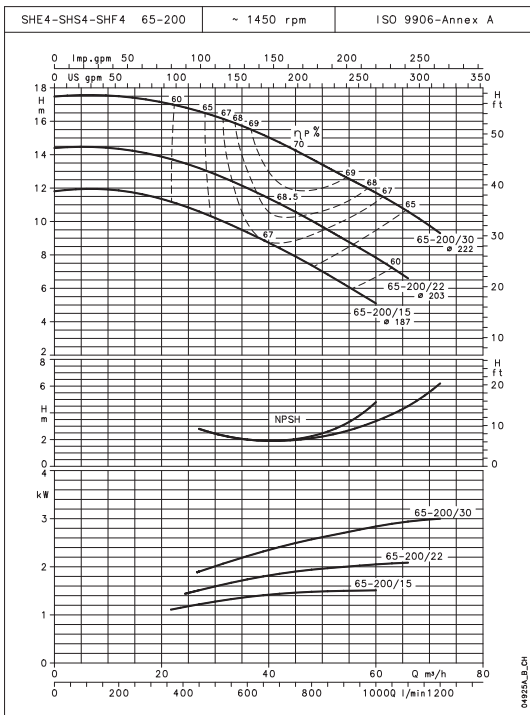
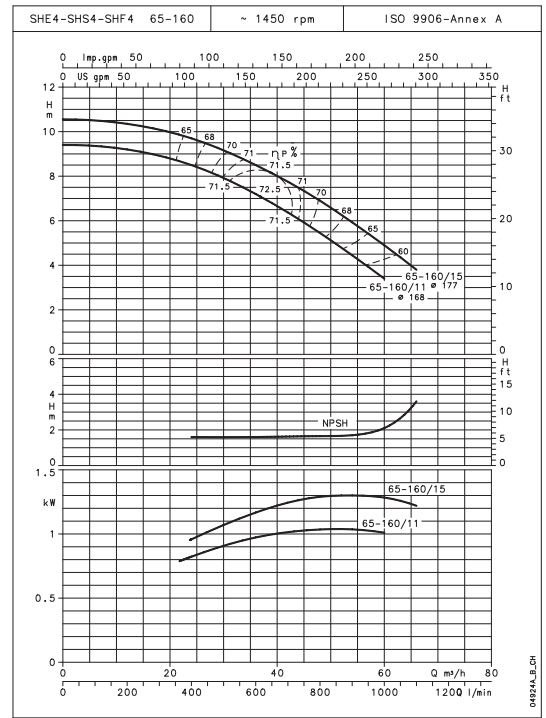
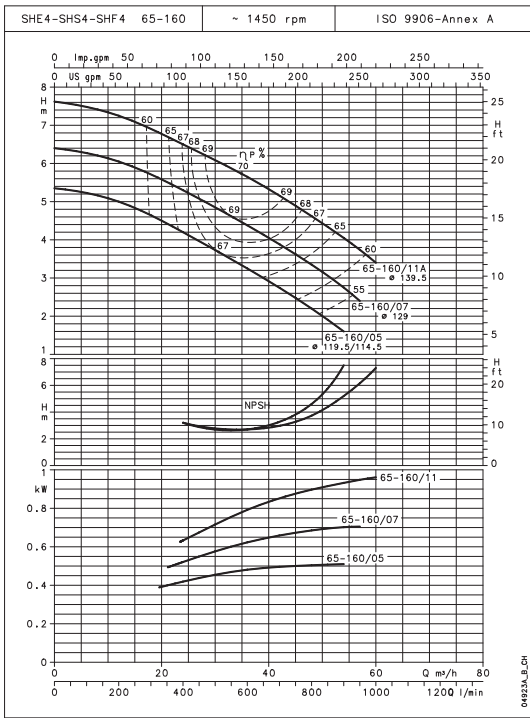

These NPSH values are valid in laboratory conditions; for practical purposes, values should be increased by a 0.5 m safety margin.

These performances are valid for liquids with density $\rho = 1.0 \text{ kg/dm}^3$ and kinematic viscosity $\nu = 1 \text{ mm}^2/\text{s}$.

SH SERIES

Operating characteristics at 50 Hz, 4 poles

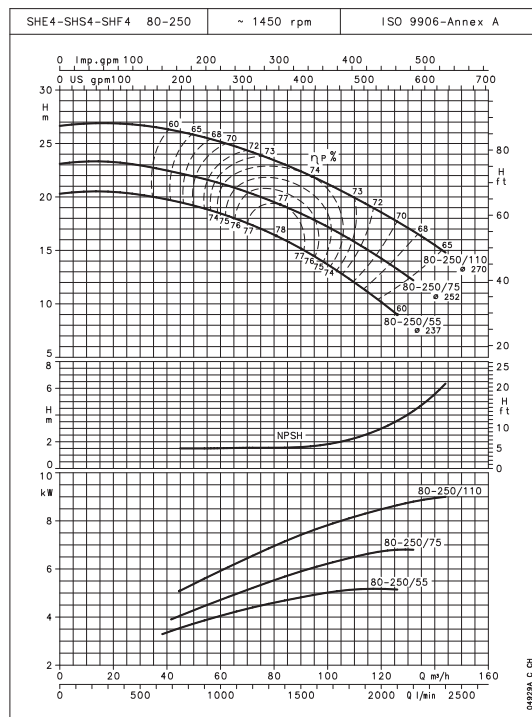
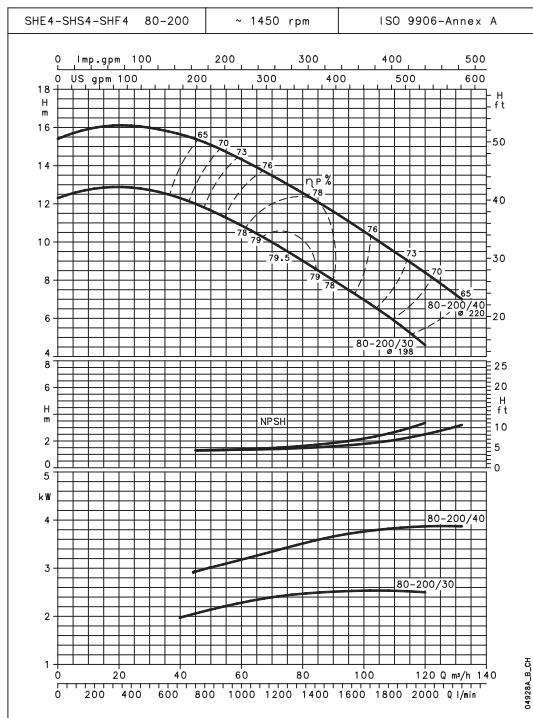
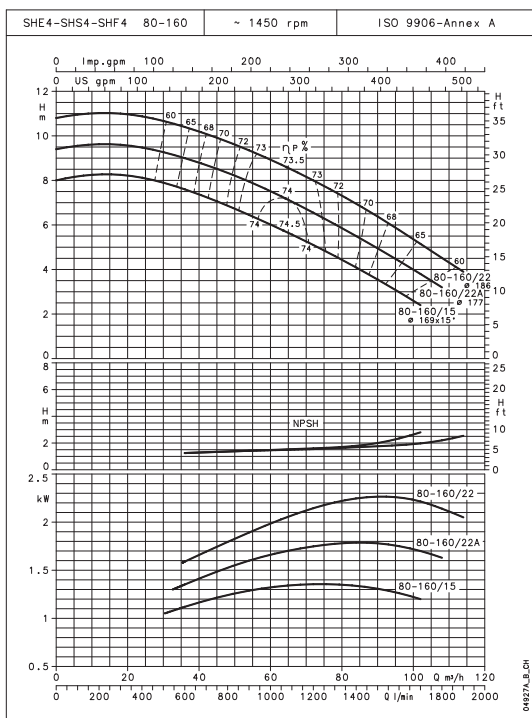

These NPSH values are valid in laboratory conditions; for practical purposes, values should be increased by a 0.5 m safety margin.

These performances are valid for liquids with density $\rho = 1.0 \text{ kg/dm}^3$ and kinematic viscosity $\nu = 1 \text{ mm}^2/\text{s}$.

SHE SERIES

Dimensions and weights at 50 Hz, 2 poles

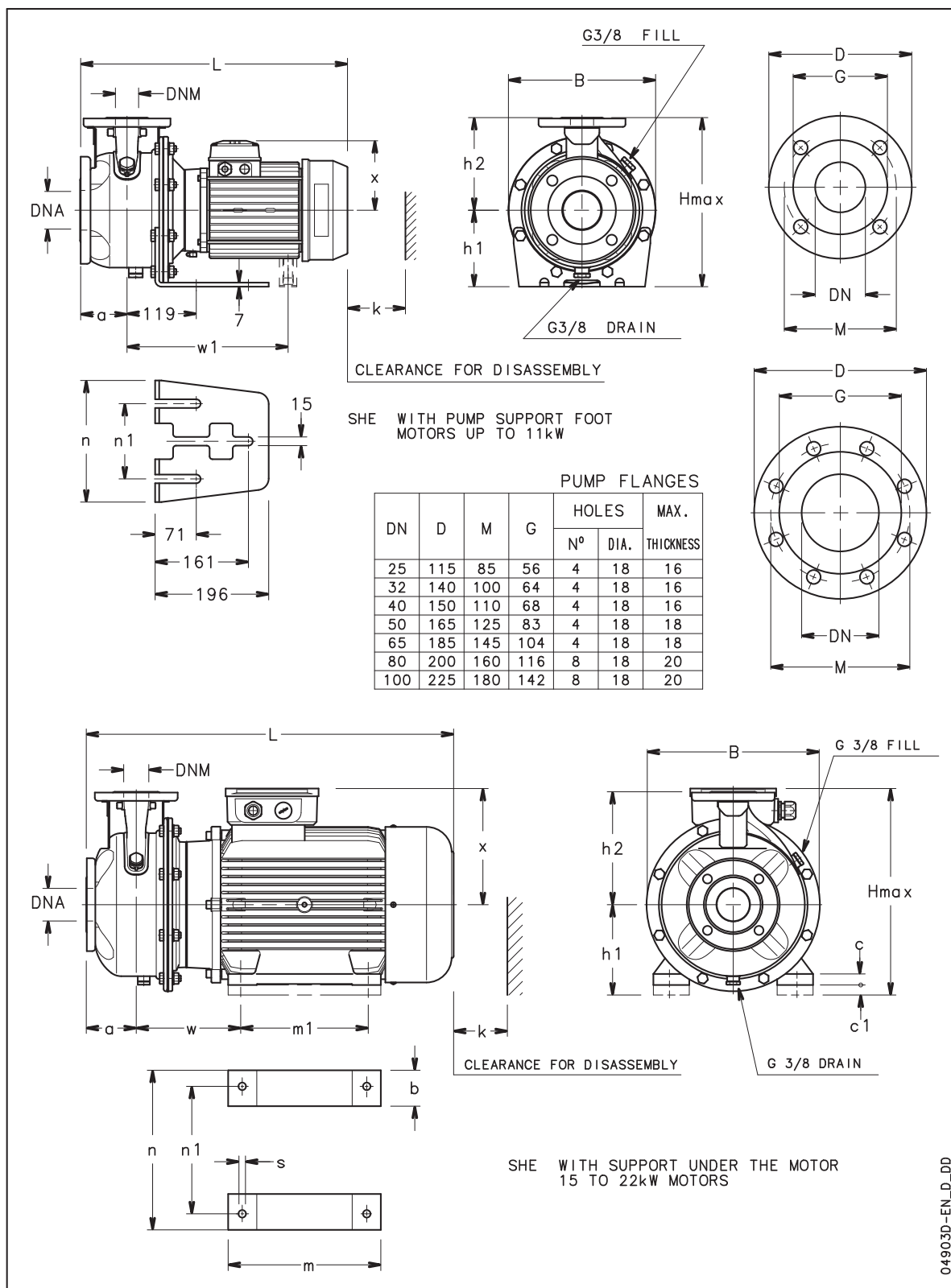

SHE SERIES

Dimensions and weights at 50 Hz, 2 poles

PUMP TYPE	DIMENSIONS (mm)															B	H max	L	k	WEIGHT kg	
	PUMP					SUPPORT															
	DNM	DNA	a	h2	w	w1	x	b	c	c1	h1	m	m1	n	n1						s
SHE 25-125/07	25	50	80	140	-	-	129	-	-	-	160	-	-	190	130	-	218	300	443	98	20
SHE 25-125/11	25	50	80	140	-	-	129	-	-	-	160	-	-	190	130	-	218	300	443	98	22
SHE 25-160/15	25	50	80	160	-	-	134	-	-	-	160	-	-	210	130	-	253	320	478	98	28
SHE 25-160/22	25	50	80	160	-	-	134	-	-	-	160	-	-	210	130	-	253	320	478	98	29
SHE 25-200/30	25	50	80	180	-	-	134	-	-	-	160	-	-	230	130	-	284	340	478	98	38
SHE 25-200/40	25	50	80	180	-	-	154	-	-	-	160	-	-	230	130	-	284	340	499	98	41
SHE 25-250/55	25	50	100	225	-	-	168	-	-	-	180	-	-	265	130	-	345	405	553	98	66
SHE 25-250/75	25	50	100	225	-	305	191	-	-	-	180	-	-	265	130	-	345	405	567	98	84
SHE 25-250/110	25	50	100	225	-	343	191	-	-	-	180	-	-	265	130	-	345	405	605	98	92
SHE 32-125/07	32	50	80	140	-	-	129	-	-	-	112	-	-	190	130	-	218	252	443	98	20
SHE 32-125/11	32	50	80	140	-	-	129	-	-	-	112	-	-	190	130	-	218	252	443	98	22
SHE 32-160/15	32	50	80	160	-	-	134	-	-	-	132	-	-	210	130	-	253	292	478	98	28
SHE 32-160/22	32	50	80	160	-	-	134	-	-	-	132	-	-	210	130	-	253	292	478	98	29
SHE 32-200/30	32	50	80	180	-	-	134	-	-	-	160	-	-	230	130	-	284	340	478	98	38
SHE 32-200/40	32	50	80	180	-	-	154	-	-	-	160	-	-	230	130	-	284	340	499	98	41
SHE 32-250/55	32	50	100	225	-	-	168	-	-	-	180	-	-	265	130	-	345	405	553	98	66
SHE 32-250/75	32	50	100	225	-	305	191	-	-	-	180	-	-	265	130	-	345	405	567	98	84
SHE 32-250/110	32	50	100	225	-	343	191	-	-	-	180	-	-	265	130	-	345	405	605	98	92
SHE 40-125/11	40	65	80	140	-	-	129	-	-	-	112	-	-	190	130	-	218	252	443	100	23
SHE 40-125/15	40	65	80	140	-	-	134	-	-	-	112	-	-	190	130	-	218	252	478	100	26
SHE 40-125/22	40	65	80	140	-	-	134	-	-	-	112	-	-	190	130	-	218	252	478	100	30
SHE 40-160/30	40	65	80	160	-	-	134	-	-	-	132	-	-	210	130	-	253	292	478	100	32
SHE 40-160/40	40	65	80	160	-	-	154	-	-	-	132	-	-	210	130	-	253	292	499	100	40
SHE 40-200/55	40	65	100	180	-	-	168	-	-	-	160	-	-	230	130	-	284	340	553	100	52
SHE 40-200/75	40	65	100	180	-	305	191	-	-	-	160	-	-	230	130	-	284	340	567	100	65
SHE 40-250/92	40	65	100	225	-	343	191	-	-	-	180	-	-	265	130	-	345	405	605	107	89
SHE 40-250/110	40	65	100	225	-	343	191	-	-	-	180	-	-	265	130	-	345	405	605	107	94
SHE 40-250/150	40	65	100	225	208	-	240	49	5	20	180	304	210	304	254	15	345	420	694	107	130
SHE 50-125/22	50	65	100	160	-	-	134	-	-	-	132	-	-	210	130	-	253	292	498	104	30
SHE 50-125/30	50	65	100	160	-	-	134	-	-	-	132	-	-	210	130	-	253	292	498	104	33
SHE 50-125/40	50	65	100	160	-	-	154	-	-	-	132	-	-	210	130	-	253	292	519	104	40
SHE 50-160/55	50	65	100	180	-	-	168	-	-	-	160	-	-	210	130	-	253	340	553	104	52
SHE 50-160/75	50	65	100	180	-	305	191	-	-	-	160	-	-	210	130	-	253	340	567	104	67
SHE 50-200/92	50	65	100	200	-	343	191	-	-	-	160	-	-	245	130	-	310	360	605	104	84
SHE 50-200/110	50	65	100	200	-	343	191	-	-	-	160	-	-	245	130	-	310	360	605	104	88
SHE 50-250/150	50	65	100	225	208	-	240	49	5	20	180	304	210	304	254	15	345	420	694	107	131
SHE 50-250/185	50	65	100	225	208	-	240	49	5	20	180	304	254	304	254	15	345	420	694	107	144
SHE 50-250/220	50	65	100	225	208	-	240	49	5	20	180	304	254	304	254	15	345	420	694	107	147
SHE 65-160/40	65	80	100	200	-	-	154	-	-	-	160	-	-	245	130	-	310	360	519	130	56
SHE 65-160/55	65	80	100	200	-	-	168	-	-	-	160	-	-	245	130	-	310	360	553	130	63
SHE 65-160/75	65	80	100	200	-	305	191	-	-	-	160	-	-	245	130	-	310	360	567	130	80
SHE 65-160/92	65	80	100	200	-	343	191	-	-	-	160	-	-	245	130	-	310	360	605	130	95
SHE 65-160/110	65	80	100	200	-	343	191	-	-	-	160	-	-	245	130	-	310	360	605	130	102
SHE 65-200/150	65	80	100	225	208	-	240	49	5	20	180	304	210	304	254	15	310	420	694	130	131
SHE 65-200/185	65	80	100	225	208	-	240	49	5	20	180	304	254	304	254	15	310	420	694	130	141
SHE 65-200/220	65	80	100	225	208	-	240	49	5	20	180	304	254	304	254	15	310	420	694	130	151
SHE 80-160/110	80	100	125	225	-	343	191	-	-	-	180	-	-	265	130	-	345	405	630	160	94
SHE 80-160/150	80	100	125	225	208	-	240	49	5	20	180	304	210	304	254	15	345	420	719	160	128
SHE 80-160/185	80	100	125	225	208	-	240	49	5	20	180	304	254	304	254	15	345	420	719	160	139
SHE 80-200/220	80	100	125	250	208	-	240	49	5	20	180	304	254	304	254	15	345	430	719	160	156

sh-she-2p50-en_d_td

SHS SERIES

Dimensions and weights at 50 Hz, 2 poles

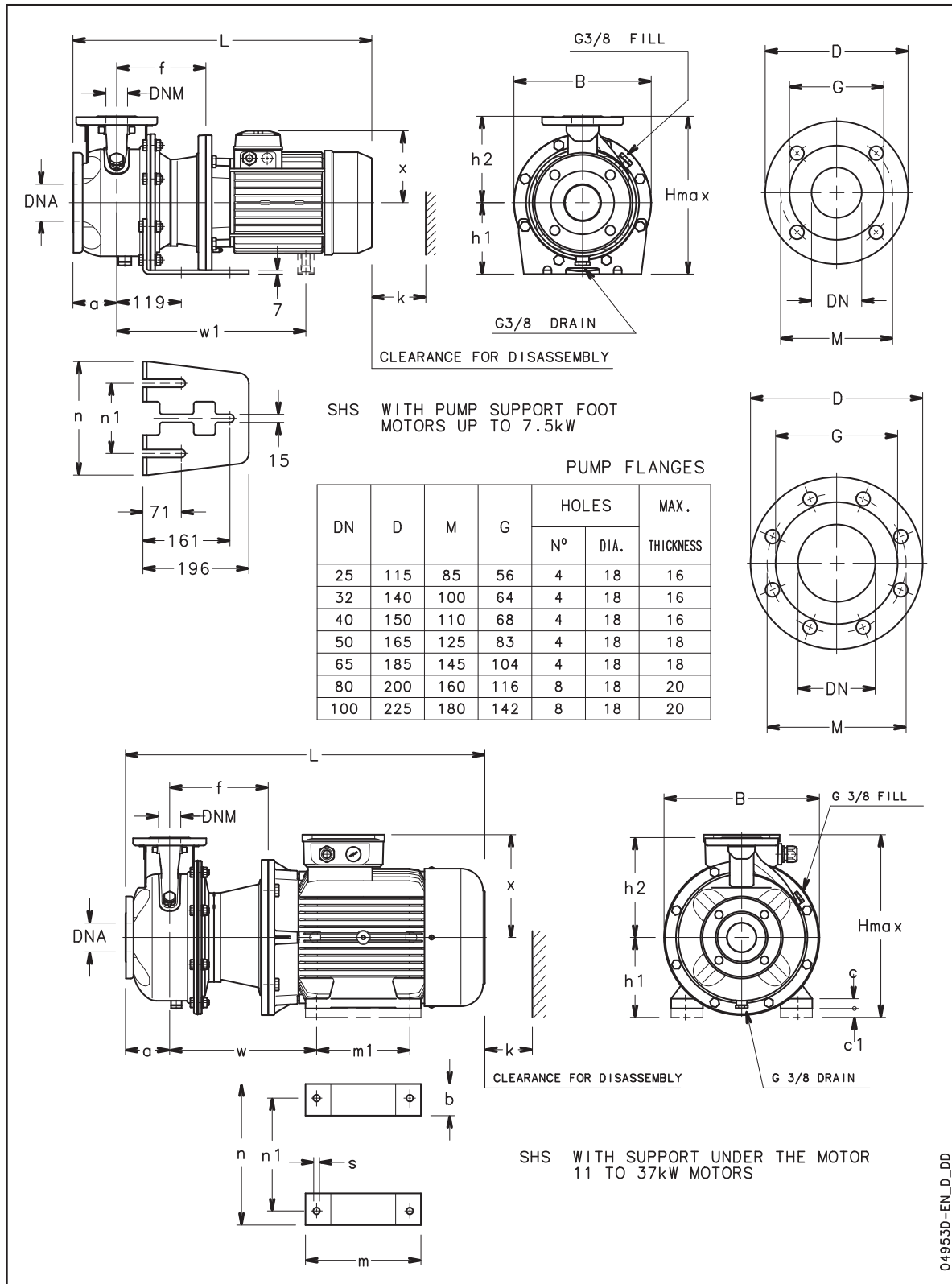

SHS SERIES

Dimensions and weights at 50 Hz, 2 poles

PUMP TYPE	DIMENSIONS (mm)																			B	H max	L	k	WEIGHT kg
	PUMP									SUPPORT														
	DNM	DNA	a	f	h2	w	w1	x	b	c	c1	h1	m	m1	n	n1	s							
SHS 25-125/07	25	50	80	155	140	-	-	129	-	-	-	160	-	-	190	130	-	218	300	498	98	25		
SHS 25-125/11	25	50	80	155	140	-	-	129	-	-	-	160	-	-	190	130	-	218	300	498	98	26		
SHS 25-160/15	25	50	80	155	160	-	-	134	-	-	-	160	-	-	210	130	-	253	320	533	98	31		
SHS 25-160/22	25	50	80	155	160	-	-	134	-	-	-	160	-	-	210	130	-	253	320	533	98	33		
SHS 25-200/30	25	50	80	165	180	-	-	154	-	-	-	160	-	-	230	130	-	284	340	543	98	44		
SHS 25-200/40	25	50	80	165	180	-	-	154	-	-	-	160	-	-	230	130	-	284	340	564	98	51		
SHS 25-250/55	25	50	100	192	225	-	399	168	-	-	-	180	-	-	265	130	-	345	405	667	98	77		
SHS 25-250/75	25	50	100	192	225	-	397	191	-	-	-	180	-	-	265	130	-	345	405	659	98	91		
SHS 25-250/110	25	50	100	222	225	330	-	240	49	5	20	180	304	210	304	254	15	350	420	816	98	130		
SHS 32-125/07	32	50	80	155	140	-	-	129	-	-	-	112	-	-	190	130	-	218	252	498	98	25		
SHS 32-125/11	32	50	80	155	140	-	-	129	-	-	-	112	-	-	190	130	-	218	252	498	98	26		
SHS 32-160/15	32	50	80	155	160	-	-	134	-	-	-	132	-	-	210	130	-	253	292	533	98	31		
SHS 32-160/22	32	50	80	155	160	-	-	134	-	-	-	132	-	-	210	130	-	253	292	533	98	33		
SHS 32-200/30	32	50	80	165	180	-	-	134	-	-	-	160	-	-	230	130	-	284	340	543	98	44		
SHS 32-200/40	32	50	80	165	180	-	-	154	-	-	-	160	-	-	230	130	-	284	340	564	98	51		
SHS 32-250/55	32	50	100	192	225	-	399	168	-	-	-	180	-	-	265	130	-	345	405	667	98	77		
SHS 32-250/75	32	50	100	192	225	-	397	191	-	-	-	180	-	-	265	130	-	345	405	659	98	91		
SHS 32-250/110	32	50	100	222	225	330	-	240	49	5	20	180	304	210	304	254	15	350	420	816	98	130		
SHS 40-125/11	40	65	80	155	140	-	-	129	-	-	-	112	-	-	190	130	-	218	252	498	100	27		
SHS 40-125/15	40	65	80	155	140	-	-	134	-	-	-	112	-	-	190	130	-	218	252	533	100	29		
SHS 40-125/22	40	65	80	155	140	-	-	134	-	-	-	112	-	-	190	130	-	218	252	533	100	32		
SHS 40-160/30	40	65	80	165	160	-	-	134	-	-	-	132	-	-	210	130	-	253	292	543	100	42		
SHS 40-160/40	40	65	80	165	160	-	-	154	-	-	-	132	-	-	210	130	-	253	292	564	100	48		
SHS 40-200/55	40	65	100	192	180	-	399	168	-	-	-	160	-	-	230	130	-	300	340	667	100	63		
SHS 40-200/75	40	65	100	192	180	-	397	191	-	-	-	160	-	-	230	130	-	300	340	659	100	80		
SHS 40-250/110A	40	65	100	222	225	330	-	240	49	5	20	180	304	210	304	254	15	350	420	816	107	129		
SHS 40-250/110	40	65	100	222	225	330	-	240	49	5	20	180	304	210	304	254	15	350	420	816	107	129		
SHS 40-250/150	40	65	100	222	225	330	-	240	49	5	20	180	304	210	304	254	15	350	420	816	107	142		
SHS 50-125/22	50	65	100	155	160	-	-	134	-	-	-	132	-	-	210	130	-	253	292	553	104	36		
SHS 50-125/30	50	65	100	165	160	-	-	134	-	-	-	132	-	-	210	130	-	253	292	563	104	37		
SHS 50-125/40	50	65	100	165	160	-	-	154	-	-	-	132	-	-	210	130	-	253	292	584	104	48		
SHS 50-160/55	50	65	100	192	180	-	399	168	-	-	-	160	-	-	210	130	-	300	340	667	104	62		
SHS 50-160/75	50	65	100	192	180	-	397	191	-	-	-	160	-	-	210	130	-	300	340	659	104	81		
SHS 50-200/110A	50	65	100	222	200	330	-	240	49	5	20	180	304	210	304	254	15	350	420	816	104	126		
SHS 50-200/110	50	65	100	222	200	330	-	240	49	5	20	180	304	210	304	254	15	350	420	816	104	130		
SHS 50-250/150	50	65	100	222	225	330	-	240	49	5	20	180	304	210	304	254	15	350	420	816	107	148		
SHS 50-250/185	50	65	100	222	225	330	-	240	49	5	20	180	304	254	304	254	15	350	420	816	107	156		
SHS 50-250/220	50	65	100	222	225	330	-	240	49	5	20	180	304	254	304	254	15	350	420	816	107	162		
SHS 65-160/40	65	80	100	165	200	-	-	154	-	-	-	160	-	-	245	130	-	310	360	584	130	60		
SHS 65-160/55	65	80	100	192	200	-	399	168	-	-	-	160	-	-	245	130	-	310	360	667	130	78		
SHS 65-160/75	65	80	100	192	200	-	397	191	-	-	-	160	-	-	245	130	-	310	360	659	130	93		
SHS 65-160/110A	65	80	100	222	200	330	-	240	49	5	20	180	304	210	304	254	15	350	420	816	130	116		
SHS 65-160/110	65	80	100	222	200	330	-	240	49	5	20	180	304	210	304	254	15	350	420	816	130	120		
SHS 65-200/150	65	80	100	222	225	330	-	240	49	5	20	180	304	210	304	254	15	350	420	816	130	147		
SHS 65-200/185	65	80	100	222	225	330	-	240	49	5	20	180	304	254	304	254	15	350	420	816	130	153		
SHS 65-200/220	65	80	100	222	225	330	-	240	49	5	20	180	304	254	304	254	15	350	420	816	130	167		
SHS 65-250/300	65	80	100	228	250	361	-	317	82	30	-	200	370	305	385	318	18	402	517	985	140	290		
SHS 65-250/370	65	80	100	228	250	361	-	317	82	30	-	200	370	305	385	318	18	402	517	985	140	322		
SHS 80-160/110	80	100	125	222	225	330	-	240	49	5	20	180	304	210	304	254	15	350	420	841	160	116		
SHS 80-160/150	80	100	125	222	225	330	-	240	49	5	20	180	304	210	304	254	15	350	420	841	160	152		
SHS 80-160/185	80	100	125	222	225	330	-	240	49	5	20	180	304	254	304	254	15	350	420	841	160	160		
SHS 80-200/220	80	100	125	222	250	330	-	240	49	5	20	180	304	254	304	254	15	350	430	841	160	162		
SHS 80-200/300	80	100	125	228	250	361	-	317	82	30	-	200	370	305	385	318	18	402	517	985	160	312		
SHS 80-200/370	80	100	125	228	250	361	-	317	82	30	-	200	370	305	385	318	18	402	517	985	160	317		

sh-shs-2p50-en_e_td

SHE4 SERIES

Dimensions and weights at 50 Hz, 4 poles

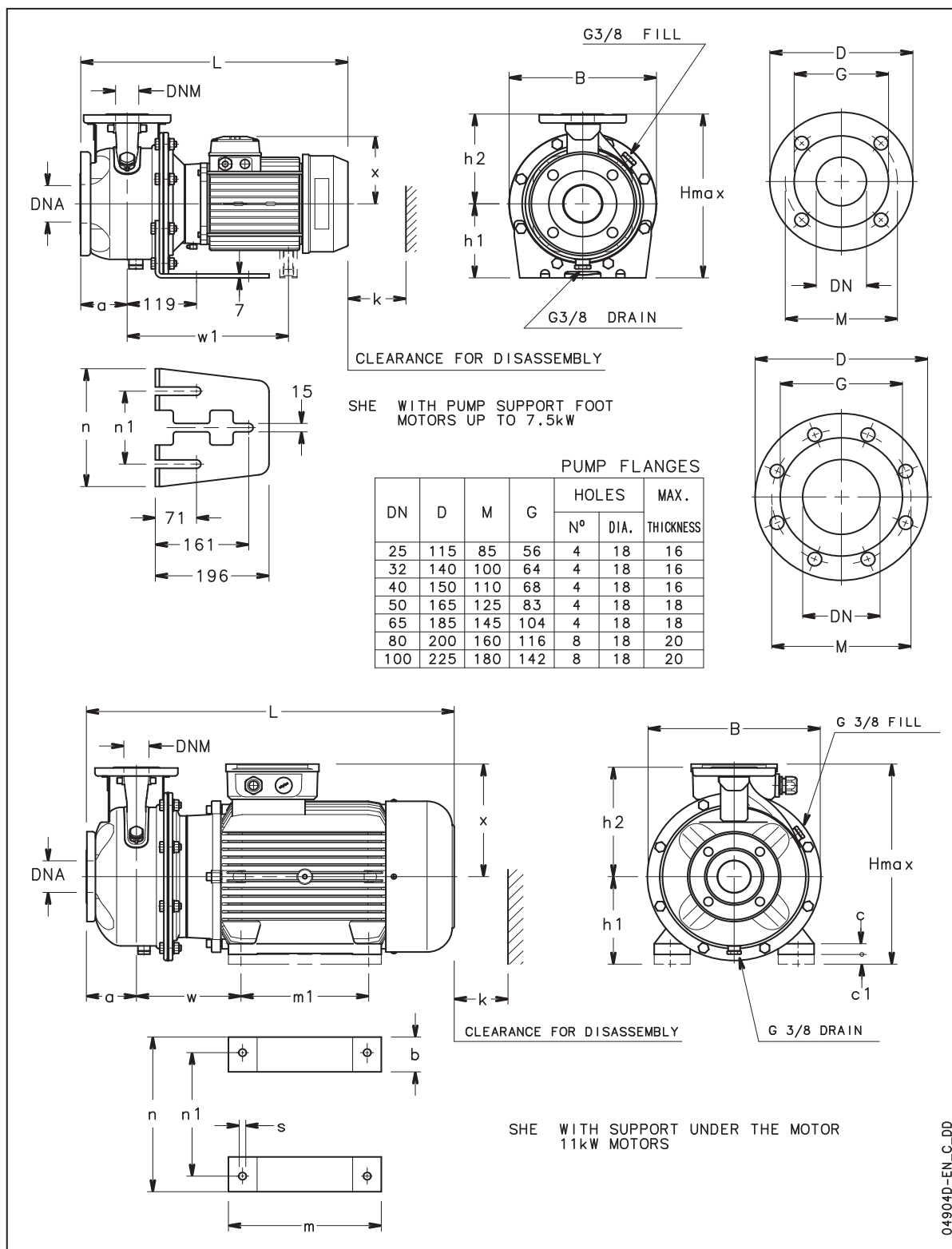

SHE4 SERIES

Dimensions and weights at 50 Hz, 4 poles

PUMP TYPE	DIMENSIONS (mm)																B	H	L	k	WEIGHT kg
	PUMP		PUMP									SUPPORT									
	DNM	DNA	a	h2	w	w1	x	b	c	c1	h1	m	m1	n	n1	s					
SHE4 25-125/02A	25	50	80	140	-	-	121	-	-	-	160	-	-	190	130	-	218	300	411	98	15
SHE4 25-125/02	25	50	80	140	-	-	121	-	-	-	160	-	-	190	130	-	218	300	411	98	16
SHE4 25-160/02	25	50	80	160	-	-	121	-	-	-	160	-	-	210	130	-	253	320	411	98	18
SHE4 25-160/03	25	50	80	160	-	-	121	-	-	-	160	-	-	210	130	-	253	320	411	98	19
SHE4 25-200/03	25	50	80	180	-	-	121	-	-	-	160	-	-	230	130	-	284	340	411	98	26
SHE4 25-200/05	25	50	80	180	-	-	129	-	-	-	160	-	-	230	130	-	284	340	443	98	27
SHE4 25-250/07	25	50	100	225	-	-	128	-	-	-	180	-	-	265	130	-	345	405	431	98	42
SHE4 25-250/11	25	50	100	225	-	-	134	-	-	-	180	-	-	265	130	-	345	405	498	98	49
SHE4 25-250/15	25	50	100	225	-	-	134	-	-	-	180	-	-	265	130	-	345	405	498	98	51
SHE4 32-125/02A	32	50	80	140	-	-	121	-	-	-	112	-	-	190	130	-	218	252	411	98	15
SHE4 32-125/02	32	50	80	140	-	-	121	-	-	-	112	-	-	190	130	-	218	252	411	98	16
SHE4 32-160/02	32	50	80	160	-	-	121	-	-	-	132	-	-	210	130	-	253	292	411	98	18
SHE4 32-160/03	32	50	80	160	-	-	121	-	-	-	132	-	-	210	130	-	253	292	411	98	19
SHE4 32-200/03	32	50	80	180	-	-	121	-	-	-	160	-	-	230	130	-	284	340	411	98	26
SHE4 32-200/05	32	50	80	180	-	-	129	-	-	-	160	-	-	230	130	-	284	340	443	98	27
SHE4 32-250/07	32	50	100	225	-	-	128	-	-	-	180	-	-	265	130	-	345	405	431	98	42
SHE4 32-250/11	32	50	100	225	-	-	134	-	-	-	180	-	-	265	130	-	345	405	498	98	49
SHE4 32-250/15	32	50	100	225	-	-	134	-	-	-	180	-	-	265	130	-	345	405	498	98	51
SHE4 40-125/02A	40	65	80	140	-	-	121	-	-	-	112	-	-	190	130	-	218	252	411	100	16
SHE4 40-125/02	40	65	80	140	-	-	121	-	-	-	112	-	-	190	130	-	218	252	411	100	17
SHE4 40-125/03	40	65	80	140	-	-	121	-	-	-	112	-	-	190	130	-	218	252	411	100	18
SHE4 40-160/03	40	65	80	160	-	-	121	-	-	-	132	-	-	210	130	-	253	292	411	100	20
SHE4 40-160/05	40	65	80	160	-	-	129	-	-	-	132	-	-	210	130	-	253	292	443	100	24
SHE4 40-200/07	40	65	100	180	-	-	128	-	-	-	160	-	-	230	130	-	285	340	431	100	27
SHE4 40-200/11	40	65	100	180	-	-	134	-	-	-	160	-	-	230	130	-	285	340	498	100	35
SHE4 40-250/11	40	65	100	225	-	-	134	-	-	-	180	-	-	265	130	-	345	405	498	107	47
SHE4 40-250/15	40	65	100	225	-	-	134	-	-	-	180	-	-	265	130	-	345	405	498	107	61
SHE4 40-250/22	40	65	100	225	-	-	168	-	-	-	180	-	-	265	130	-	345	405	522	107	65
SHE4 50-125/03A	50	65	100	160	-	-	121	-	-	-	132	-	-	210	130	-	253	292	431	104	20
SHE4 50-125/03	50	65	100	160	-	-	121	-	-	-	132	-	-	210	130	-	253	292	431	104	20
SHE4 50-125/05	50	65	100	160	-	-	129	-	-	-	132	-	-	210	130	-	253	292	463	104	26
SHE4 50-160/07	50	65	100	180	-	-	128	-	-	-	160	-	-	210	130	-	253	340	431	104	30
SHE4 50-160/11	50	65	100	180	-	-	134	-	-	-	160	-	-	210	130	-	253	340	498	104	40
SHE4 50-200/11	50	65	100	200	-	-	134	-	-	-	160	-	-	245	130	-	310	360	498	104	48
SHE4 50-200/15	50	65	100	200	-	-	134	-	-	-	160	-	-	245	130	-	310	360	498	104	51
SHE4 50-250/22A	50	65	100	225	-	-	168	-	-	-	180	-	-	265	130	-	345	405	522	107	56
SHE4 50-250/22	50	65	100	225	-	-	168	-	-	-	180	-	-	265	130	-	345	405	522	107	56
SHE4 50-250/30	50	65	100	225	-	-	168	-	-	-	180	-	-	265	130	-	345	405	553	107	62
SHE4 65-160/05	65	80	100	200	-	-	129	-	-	-	160	-	-	245	130	-	310	360	463	130	32
SHE4 65-160/07	65	80	100	200	-	-	128	-	-	-	160	-	-	245	130	-	310	360	431	130	36
SHE4 65-160/11A	65	80	100	200	-	-	134	-	-	-	160	-	-	245	130	-	310	360	498	130	44
SHE4 65-160/11	65	80	100	200	-	-	134	-	-	-	160	-	-	245	130	-	310	360	498	130	45
SHE4 65-160/15	65	80	100	200	-	-	134	-	-	-	160	-	-	245	130	-	310	360	498	130	48
SHE4 65-200/15	65	80	100	225	-	-	134	-	-	-	180	-	-	245	130	-	310	405	498	130	56
SHE4 65-200/22	65	80	100	225	-	-	168	-	-	-	180	-	-	245	130	-	310	405	522	130	64
SHE4 65-200/30	65	80	100	225	-	-	168	-	-	-	180	-	-	245	130	-	310	405	553	130	64
SHE4 65-250/40	65	80	100	250	-	315	168	-	-	-	200	-	-	265	130	-	345	450	598	140	84
SHE4 65-250/55	65	80	100	250	-	343	191	-	-	-	200	-	-	265	130	-	345	450	605	140	97
SHE4 80-160/15	80	100	125	225	-	-	134	-	-	-	180	-	-	265	130	-	345	405	523	160	55
SHE4 80-160/22A	80	100	125	225	-	-	168	-	-	-	180	-	-	265	130	-	345	405	547	160	63
SHE4 80-160/22	80	100	125	225	-	-	168	-	-	-	180	-	-	265	130	-	345	405	547	160	66
SHE4 80-200/30	80	100	125	250	-	-	168	-	-	-	180	-	-	265	130	-	345	430	578	160	69
SHE4 80-200/40	80	100	125	250	-	315	168	-	-	-	180	-	-	265	130	-	345	430	623	160	88
SHE4 80-250/55	80	100	125	280	-	343	191	-	-	-	200	-	-	303	210	-	383	480	630	160	102
SHE4 80-250/75	80	100	125	280	-	343	191	-	-	-	200	-	-	303	210	-	383	480	630	160	106
SHE4 80-250/110	80	100	125	280	208	-	240	49	5	40	200	304	210	304	254	15	383	480	719	160	145

sh-she4-4p50-en_d_tld

SHS4 SERIES

Dimensions and weights at 50 Hz, 4 poles

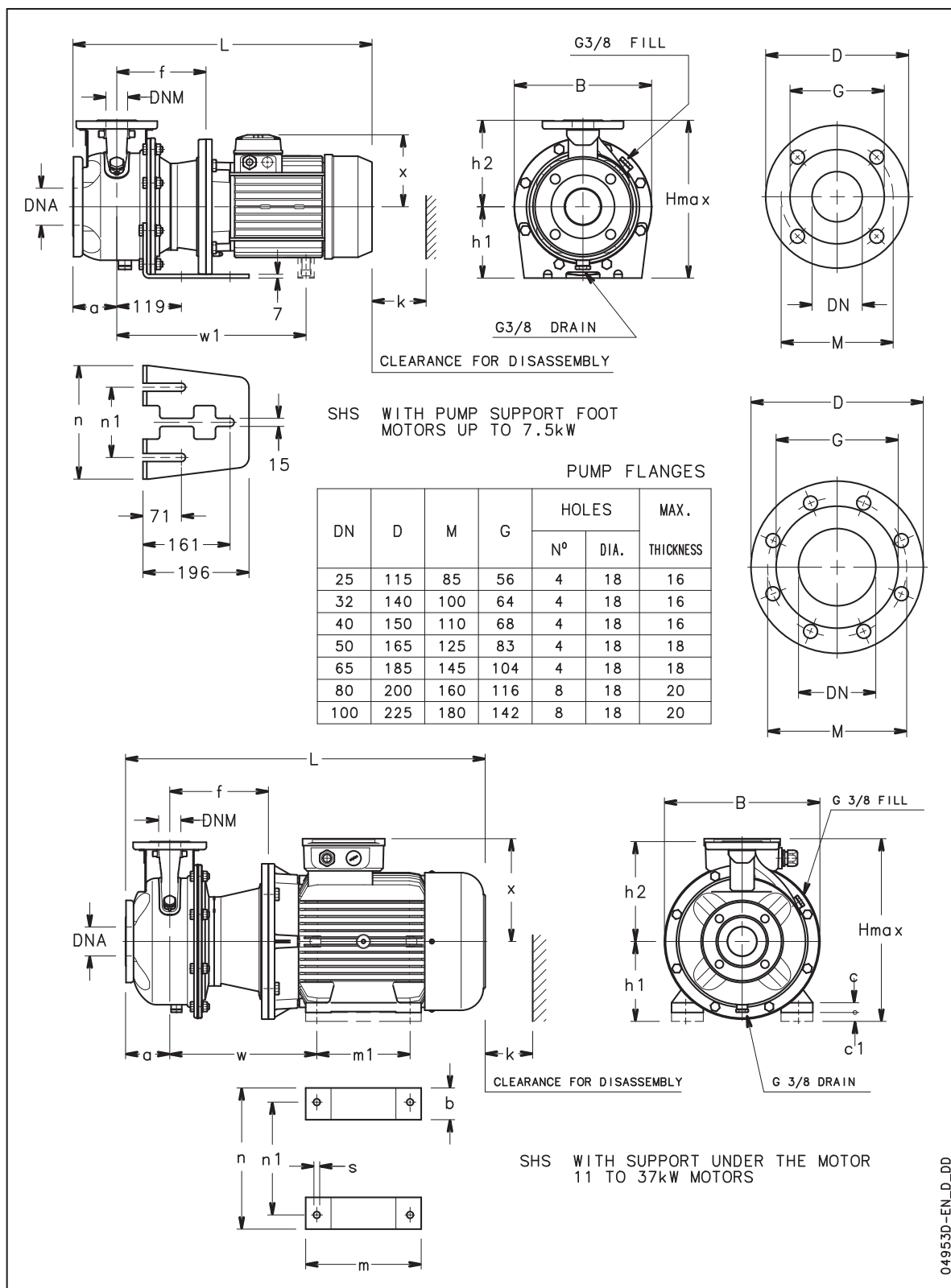

SHS4 SERIES

Dimensions and weights at 50 Hz, 4 poles

PUMP TYPE	DIMENSIONS (mm)																				WEIGHT kg	
	PUMP										SUPPORT											
	DNM	DNA	a	f	h2	w	w1	x	c	c1	h1	m	m1	n	n1	s	B	H max	L	k		
SHS4 25-250/07	25	50	100	155	225	-	-	128	-	-	-	180	-	-	265	130	-	345	405	486	98	42
SHS4 25-250/11	25	50	100	155	225	-	-	134	-	-	-	180	-	-	265	130	-	345	405	553	98	49
SHS4 25-250/15	25	50	100	155	225	-	-	134	-	-	-	180	-	-	265	130	-	345	405	553	98	50
SHS4 32-250/07	32	50	100	155	225	-	-	128	-	-	-	180	-	-	265	130	-	345	405	486	98	42
SHS4 32-250/11	32	50	100	155	225	-	-	134	-	-	-	180	-	-	265	130	-	345	405	553	98	49
SHS4 32-250/15	32	50	100	155	225	-	-	134	-	-	-	180	-	-	265	130	-	345	405	553	98	50
SHS4 40-200/07	40	65	100	155	180	-	-	128	-	-	-	160	-	-	230	130	-	284	340	486	100	31
SHS4 40-200/11	40	65	100	155	180	-	-	134	-	-	-	160	-	-	230	130	-	284	340	553	100	37
SHS4 40-250/11	40	65	100	155	225	-	-	134	-	-	-	180	-	-	265	130	-	345	405	553	107	51
SHS4 40-250/15	40	65	100	155	225	-	-	134	-	-	-	180	-	-	265	130	-	345	405	553	107	64
SHS4 40-250/22	40	65	100	165	225	-	-	168	-	-	-	180	-	-	265	130	-	345	405	587	107	68
SHS4 50-160/07	50	65	100	155	180	-	-	128	-	-	-	160	-	-	210	130	-	253	340	486	104	30
SHS4 50-160/11	50	65	100	155	180	-	-	134	-	-	-	160	-	-	210	130	-	253	340	553	104	36
SHS4 50-200/11	50	65	100	155	200	-	-	134	-	-	-	160	-	-	245	130	-	310	360	553	104	49
SHS4 50-200/15	50	65	100	155	200	-	-	134	-	-	-	160	-	-	245	130	-	310	360	553	104	52
SHS4 50-250/22A	50	65	100	165	225	-	-	168	-	-	-	180	-	-	265	130	-	345	405	587	107	58
SHS4 50-250/22	50	65	100	165	225	-	-	168	-	-	-	180	-	-	265	130	-	345	405	587	107	59
SHS4 50-250/30	50	65	100	165	225	-	-	168	-	-	-	180	-	-	265	130	-	345	405	618	107	65
SHS4 65-160/05	65	80	100	155	200	-	-	129	-	-	-	160	-	-	245	130	-	310	360	518	130	34
SHS4 65-160/07	65	80	100	155	200	-	-	128	-	-	-	160	-	-	245	130	-	310	360	486	130	38
SHS4 65-160/11A	65	80	100	155	200	-	-	134	-	-	-	160	-	-	245	130	-	310	360	553	130	46
SHS4 65-160/11	65	80	100	155	200	-	-	134	-	-	-	160	-	-	245	130	-	310	360	553	130	48
SHS4 65-160/15	65	80	100	155	200	-	-	134	-	-	-	160	-	-	245	130	-	310	360	553	130	51
SHS4 65-200/15	65	80	100	155	225	-	-	134	-	-	-	180	-	-	245	130	-	310	405	553	130	54
SHS4 65-200/22	65	80	100	165	225	-	-	168	-	-	-	180	-	-	245	130	-	310	405	587	130	71
SHS4 65-200/30	65	80	100	165	225	-	-	168	-	-	-	180	-	-	245	130	-	310	405	618	130	72
SHS4 65-250/40	65	80	100	165	250	-	380	168	-	-	-	200	-	-	265	130	-	345	450	663	140	97
SHS4 65-250/55	65	80	100	192	250	-	435	191	-	-	-	200	-	-	265	130	-	345	450	697	140	104
SHS4 80-160/15	80	100	125	155	225	-	-	134	-	-	-	180	-	-	265	130	-	345	405	578	160	59
SHS4 80-160/22A	80	100	125	165	225	-	-	168	-	-	-	180	-	-	265	130	-	345	405	612	160	67
SHS4 80-160/22	80	100	125	165	225	-	-	168	-	-	-	180	-	-	265	130	-	345	405	612	160	67
SHS4 80-200/30	80	100	125	165	250	-	-	168	-	-	-	180	-	-	265	130	-	345	430	643	160	72
SHS4 80-200/40	80	100	125	165	250	-	380	168	-	-	-	180	-	-	265	130	-	345	430	688	160	88
SHS4 80-250/55	80	100	125	192	280	-	435	191	-	-	-	200	-	-	303	210	-	383	480	722	160	107
SHS4 80-250/75	80	100	125	192	280	-	435	191	-	-	-	200	-	-	303	210	-	383	480	722	160	113
SHS4 80-250/110	80	100	125	222	280	330	-	240	49	5	40	200	304	210	304	254	15	383	480	841	160	153

sh-shs4-4p50-en_d_td

