

ABA

Lifting Point for Welding



Full WLL in any direction
with 4:1 design factor

100% Electro-magnetic
crack detection tested

Patented wear markings
on the inside and on the
outside

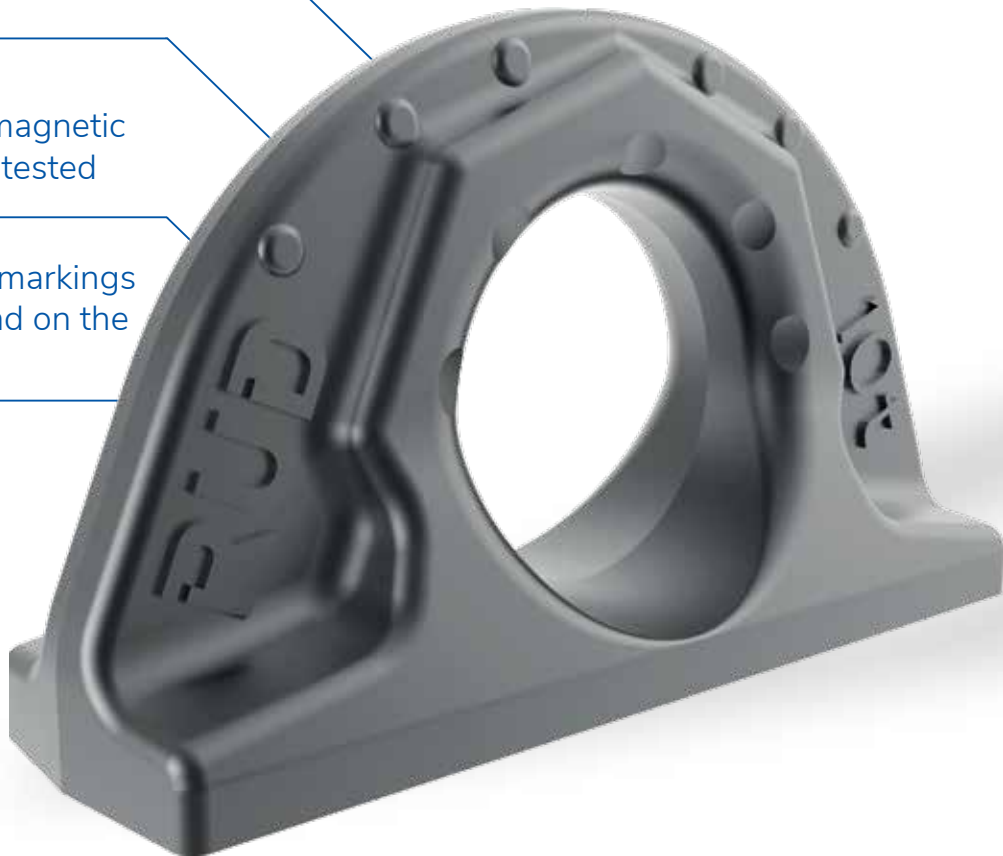

Product features / ABA Lifting Point



- ✓ Full WLL in any direction with 4:1 design factor
- ✓ 100% Electro-magnetic crack detection tested
- ✓ Manufactured in Germany using high tensile CrNiMo - steel
- ✓ Rated capacity can be increased by 100% in specific lashing capacities
- ✓ Clear marking of the WLL
- ✓ Patented wear markings on the inside and on the outside
- ✓ Complies with EN 1677
- ✓ Temperature Range -40°C to 200°C no reduction in WLL

TYPE	WLL[t]	A	B	C	D	E	F	T	WEIGHT [kg]	Reference Number
ABA 0.8 t	0.8	22	12	70	32	12	50	32	0.2	7907698
ABA 1.6 t	1.6	30	16	100	35	16	57	42	0.45	7900352
ABA 3.2 t	3.2	41	23	137	50	21	80	59	1.15	7900353
ABA 5 t	5.0	51	27	172	60	28	99	72	2.26	7900354
ABA 10 t	10.0	70	38	228	80	35	130	95	5.37	7900355
ABA 20 t	20.0	90	52	272	115	40	175	135	10.72	7902174
ABA 31.5 t	31.5	108	64	320	130	50	204	154	18.33	7902175

Dimensions and specifications subject to change

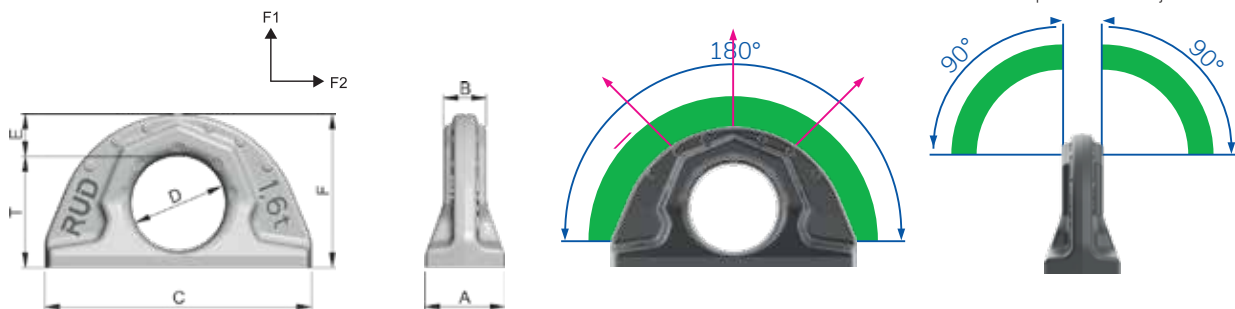

SAFE



UNSAFE

Head Office
12 Commerce Place, Larapinta QLD 4110
T: +61 7 3809 1300 F: +61 7 3809 1301

WA Office: Perth
107 Broadway, Bassendean WA 6054
T: +61 8 6278 1788 F: +61 8 6278 4788



E: sales@rud.com.au
W: www.rud.com.au
ABN: 74 010 547 949