

MECH-N-AIR

Construction & Access Equipment

SALES | SERVICE | TRANSPORT | MODIFICATIONS | MAJOR CERTIFICATION

Fully equipped workshop with drive through access & onsite breakdown / maintenance.
Construction & access equipment major certifications are completed in our workshop.

New & secondhand construction & access equipment including:
Excavators, skid steers & dumpers, scissor lift, boom lifts, leg rammers, trowels, pumps, saws, compressors and custom fabrications.



**WACKER
NEUSON**



AUTHORISED DEALER



**WACKER
NEUSON**



TRACTO-TECHNIK

EWPA

TSHA

TRANSPORTATION

We have a custom built Kenworth tilt tray and low loader for all your transportation requirements.



R210



R210BA



R210HY



Accessori Standard

Motore benzina R210/R210HY
Batteria R210BA/R210HY
Motore elettrico R210/R210BA/R210HY
Contaore
Presa aria/acqua
Presa elettrica
Filocomando
Rotazione cesto

Accessori Optional

Motore diesel R210/R210HY
Elettropompa di emergenza 12/24V
Radiocomando
Autolivellamento stabilizzatori
Cingoli antitraccia
Verniciatura speciale
Interfono
Cesto in vetroresina
Isolamento (1.000V)
Faro di lavoro sul cesto
Inclinometro con allarme acustico
Set 4 pedane per stabilizzatori

Standard Accessories

Petrol engine R210/R210HY
Battery R210BA/R210HY
Electric motor R210/R210BA/R210HY
Hour counter
Air/water plug
Electrical plug
Cable control
Cage rotation

Optional Accessories

Diesel engine R210/R210HY
Emergency pump 12/24V
Radiocontrol
Stabilizers self-leveling
Non-marking tracks
Special painting
Interphone
Fiberglass basket
Basket insulation (1.000V)
Working lamp on the basket
Inclinometer with acoustic alarm
4 pads for stabilizers

Accessoires Standard

Moteur essence R210/R210HY
Batterie R210BA/R210HY
Moteur électrique R210/R210BA/R210HY
Compteur des heures
Prise air /eau dans le panier
Prise électrique
Commande à distance
Rotation panier

Accessoires Optionnels

Moteur diesel R210/R210HY
Pompe d'urgence 12/24V
Radiocommande
Auto-nivellement stabilisateurs
Chenilles non-marquants
Peinture spéciale
Interphone
Panier en fibre de verre
Isolation panier (1.000V)
Lampe de travail sur le panier
Inclinomètre avec alarme sonore
4 plates pour stabilisateurs

Accesorios Estándar

Motor gasolina R210/R210HY
Batería R210BA/R210HY
Motor eléctrico R210/R210BA/R210HY
Cuenta-horas
Toma aire/agua
Toma eléctrica
Mando a distancia
Rotación cesta

Accesorios Opcionales

Motor diesel R210/R210HY
Bomba eléctrica de emergencia 12/24V
Radiomando
Autonivelación estabilizadores
Orugas que no dejan huellas
Pintura especial
Intercomunicador
Cesta en fibra de vidrio
Aislamiento (1.000V)
Luz de trabajo en la cesta
Sensor de inclinación con alarma sonora
4 Platos de apoyo para estabilizadores

Standardzubehöre

Benzinmotor R210/R210HY
Batterie R210BA/R210HY
Elektromotor R210/R210BA/R210HY
Stundenzählwerk
Anschluss Luft/Wasser
Steckdose
Fernsteuerung
Korbdrehung

Sonderzubehöre

Dieselmotor R210/R210HY
Notfallleistungspumpe 12/24V
Funksteuerung
Abstützungenselbstnivellierung
Nicht-markierende Raupenketten
Sonderlackierung
Sprechanlage
Korb aus Glasfaser
Aislamiento (1.000V)
Arbeitsscheinwerfer im Korb
Neigungsmessgerät mit akustischem Alarm
4 Unterlegplatten für Abstützungen

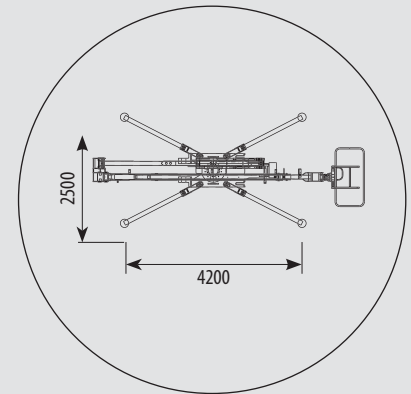
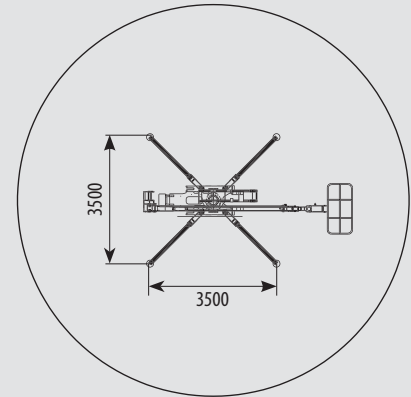
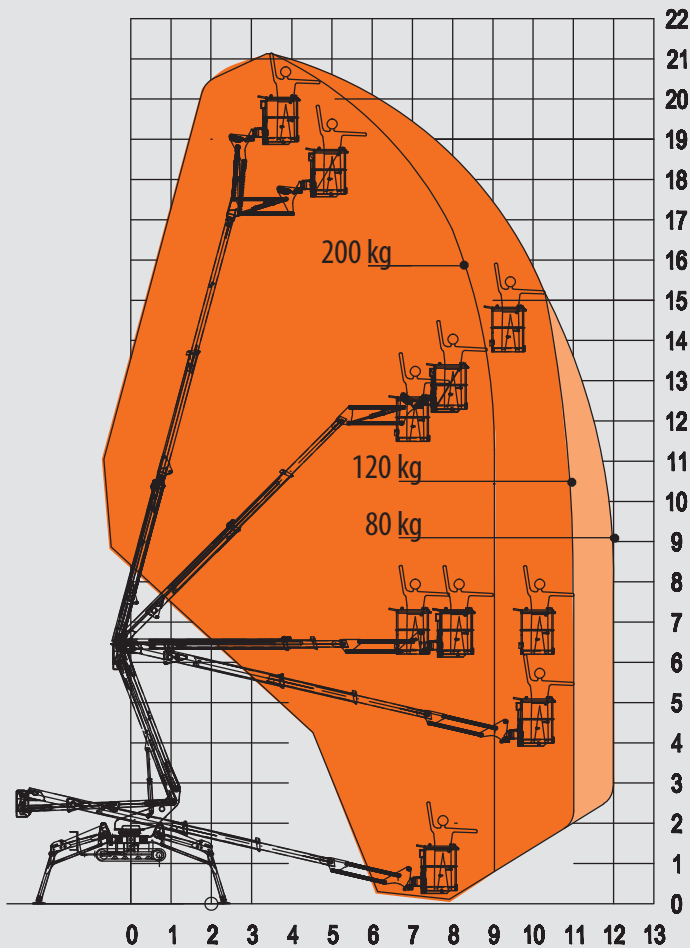
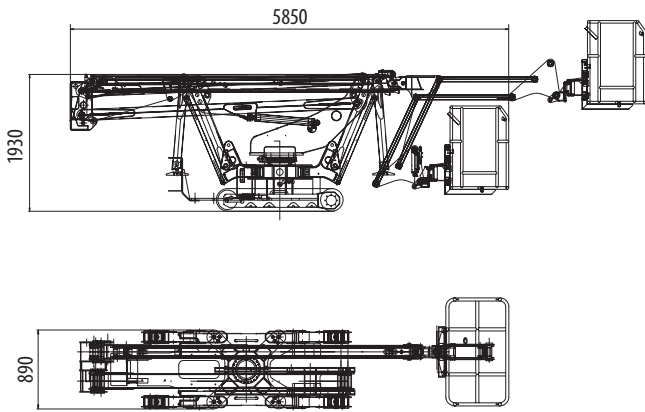

Altezza massima di lavoro	Max. working height	Hauteur max de travail	Altura max de trabajo	Max. Arbeitshöhe	21,20 m
Sbraccio massimo di lavoro	Max. working outreach	Déport max de travail	Alcance max de trabajo	Max. Arbeitsauslegung	11,00 m
Rotazione torretta	Turret rotation	Rotation tourelle	Rotación torreta	Drehturmrotation	360° N.C.
Portata massima	Max load capacity	Portée max	Capacidad de carga	Max. Tragfähigkeit	200 Kg
Comandi elettro-idraulici (Danfoss)	Electro-hydraulic controls (Danfoss)	Commandes électro-hydrauliques (Danfoss)	Mandos electrohidráulicos (Danfoss)	Elektrohydraulische Steuerungen (Danfoss)	
Massa totale	Total weight	Poids total	Peso total	Gewicht	3000 Kg
Pendenza superabile	Gradeability	Max pente admissible	Pendiente máx	Max. Steigfähigkeit	30%
Dimensioni cesto	Cage dimensions	Dimensions panier	Dimensiones cesta	Korbabmessungen	1,4 x 0,7 m
Rotazione cesto	Cage rotation	Rotation panier	Rotación cesta	Korbdrehung	90° + 90°

Dati e descrizioni sono forniti a titolo indicativo e non impegnativo

Data and descriptions are approximate and not binding

Toutes les données et descriptions sont fournies à titre indicatif, sans engagement

Los datos y las descripciones son suministrados indicativamente y sin compromiso

Abgaben und Beschreibungen sind nicht verbindlich

Legenda	Legend	Légende	Leyenda	Legende	
Batteria a trazione	Traction battery	Batterie à traction	Batería de tracción	Traktionsbatterie	
Batteria al litio	Lithium battery	Batterie au lithium	Batería de litio	Lithiumbatterie	
Motore elettrico	Electric motor	Moteur électrique	Motor eléctrico	Elektromotor	
Motore a combustione	Combustion engine	Moteur à combustion	Motor de combustión	Explosionsmotor	