

Europa Jobs Gas or Electric Rotary Rack Oven

Description

The JOBS Baking revolution – Hi-tech rotary rack ovens

Technical Features:

- EVOLVED ROTARY RACK OVENS FOR BREAD AND PASTRY PRODUCTS ideal both for large industrial productions and artisan bakers demanding the best quality and highest baking flexibility.
- SIDE HEAT EXCHANGER WITH FRONT ACCESS TO THE BURNER OR TO THE ELECTRIC HEATING ELEMENTS (all MAINTENANCE operations can be carried out from the front, from the inside or above the oven): these ovens can be installed AMONG 3 WALLS OR SIDE BY SIDE with other ovens.
- Ovens ready to accommodate 1950mm HIGH RACKS (=2 trays more if compared to regular racks) with consequent 10% extra production – obviously it is also possible to use regular racks (H=1810mm) adding the LONGER HOOK (option) or the TURNTABLE (option)
- SIDE HEAT EXCHANGER with front burner/resistances access : ideal for installation among 3 walls or in line with other ovens
- "SOLE EFFECT" RISING BAKING VENTILATION with 4 air flow outlets, better "product development" thanks to the upstream thermal exchange and the circular ventilation from bottom to top
- Practical upper HOOK rotating system (standard) for easier rack handling and oven cleaning – as an alternative: the turntable (option) or the motorized automatic rack lifter (option) ideal for liquid or very leavened products or for very heavy racks.
- New BUILT-IN DOOR GASKET SYSTEM (patented) to avoid any impact with racks and to grant better seal and longer life. Easy to be replaced (even from the baker)
- 2-section POWERFUL STEAM GENERATOR with double water injection (patented) placed next to the heat exchanger, in order to grant an excellent steam production with very fast recovery time and uniform steam distribution on the rack – ideal for short non-stop baking cycles
- COMBUSTION CHAMBER with 4 turns of fume, fully accessible for easy cleaning and consequent clean fume emission, redesigned with innovative technology ensuring excellent performances, fast recovery time and reduced consumptions (among the lowest ones in the market) – Covered by a 3-YEAR WARRANTY
- STAINLESS STEEL FRONT, BAKING CHAMBER AND EXTERNAL PANELS
- High efficiency thermal insulation thanks to compressed HD rockwool panels
- HOOD equipped with steam extractor (standard).
- DIGITAL CONTROL PANEL with 200 STORABLE PROGRAMS, colour LCD screen and integrated led display
- WEEKLY PROGRAMMABLE IGNITION system with 2 daily ignition programs.



Europa Jobs Gas or Electric Rotary Rack Oven

- Standard 3-STAGE POWER SELECTOR (Energy Saving System) for the electric versions only, allowing to adjust the oven's power according to the type of products or the intensity of the production (patented).
- Available in electric, gas or gasoil versions.
- Available in TUNNEL VERSION with 1 front and 1 rear doors (ideal for supermarkets)

Optional / Accessories

- MULTIPHASE AUTOMATIC 200-PROGRAM CONTROL PANEL with 5/10 baking phases and programmable damper
- ELECTROMECHANICAL control panel with manual damper
- 2 SPEED BAKING VENTILATION (ideal for delicate PASTRY or soft bread)
- TURNTABLE or SPECIAL TURNTABLE TO INSERT 2 SINGLE RACKS (for JOBS 128 only)
- AUTOMATIC RACK LIFTER
- LOWER HOOK for regular racks H=1810mm
- DISPLAY ON THE HOOD showing the remaining baking time and the temperature
- STAINLESS STEEL EXTRACTOR
- Natural gas, LPG, city gas or gasoil BURNER
- RACKS and TRAYS

Digital control panel with 200 storable programs, colour LCD screen and integrated led display

Europa Jobs Gas or Electric Rotary Rack Oven – Specifications

Model	Dimensions					Tray Dimensions	Power			Average Consumption / Hour		Minimum Room Height	Minimum Door Dimensions	
							Electric	Gas/Gas Oil	Electric	Electric	Gas/Gas Oil		H	L
	L	P	H	Q	Y		cm	kW	Kcal/h	kW	F	G	mm	mm
J108C	1900	1500	2350			60x80 60x90 – 65x85 70x80 – 75x80		60.000	+2,5		35.000	2850	800	2000
J108E	1600	1500	2350			2/46x66 (2/18"x26")	54		+2,5	33		2850	800	2000
J128C	2150	1700	2350	400	250	60x100 70x100 – 75x90 80x80 – 80x100 2/53x65 – 2/46x76 (2/18"x30")		80.000	+3		45.000	2850	900	2000
J128E	1800	1700	2350			2X46x61 – 2X46x66 (2X18"x26") 2X45x75 – 2X46x76 (2X18"x30") 2X47x63	70.2		+3	43		2850	900	2000

Europa Jobs Gas or Electric Rotary Rack Oven

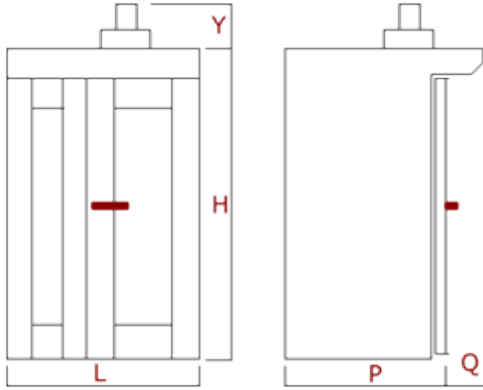

Rack – Specifications

Model	High Racks Height=1950mm		Regular Racks Height=1810mm	
	J108	J128	J108	J128
H	1950mm	1950mm	1810mm	1810mm
C	1770mm	1770mm	1585mm	1585mm
Number NR Levels	X	X	X	X
13	132 mm	132 mm	121 mm	121 mm
15	115 mm	115 mm	105 mm	105 mm
16	107 mm	107mm	99 mm	99 mm
18	95 mm	95 mm	88 mm	88 mm
20	86 mm	86 mm	79 mm	79 mm
22	77 mm	77 mm	79 mm	79 mm

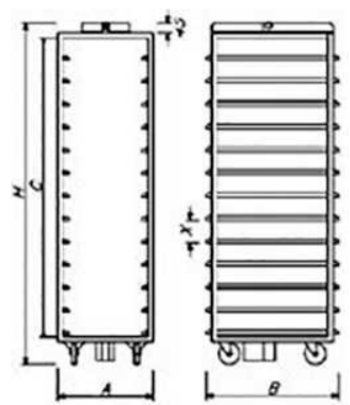

C : NR = X A: Tray Width + 60mm B: Tray Length + 20mm